

Scottish Government Demonstration Strategy: Trialling Methods for Tracking the Fine Scale Underwater Movements of Marine Mammals in Areas of Marine Renewable Energy Development

Scottish Marine and Freshwater Science Vol 7 No 14

C Sparling, D Gillespie, G Hastie, J Gordon, J Macaulay, C Malinka, M Wu and B McConnell

© Crown Copyright 2016

**Scottish Government Demonstration Strategy: Trialling Methods for
Tracking the Fine Scale Underwater Movements of Marine Mammals in
Areas of Marine Renewable Energy Development**

Scottish Marine and Freshwater Science Vol 7 No 14

Carol Sparling, Doug Gillespie, Gordon Hastie, Jonathan Gordon, Jamie
Macaulay, Chloe Malinka, Mick Wu and Bernie McConnell

Published by Marine Scotland Science

ISSN: 2043-7722

DOI: 10.7489/1759-1

Marine Scotland Science is the directorate of the Scottish Government responsible for the integrated management of Scotland's seas. Marine Scotland Science (formerly Fisheries Research Services) provides expert scientific and technical advice on marine and fisheries issues. Scottish Marine and Freshwater Science is a series of reports that publishes the results of research and monitoring carried out by Marine Scotland Science. It also publishes results of marine and freshwater scientific work that has been carried out for Marine Scotland under external commission. These reports are not subject to formal external peer-review.

This report presents the results of marine and freshwater scientific work carried out for Marine Scotland under external commission.

Crown copyright

You may use or re-use this information (not including logos) free of charge in any format or medium, under the terms of the Open Government License. See:

www.nationalarchives.gov.uk/doc/open-government-licence/

Scottish Government Demonstration Strategy: Trialling methods for tracking the fine scale underwater movements of marine mammals in areas of marine renewable energy development

Carol Sparling, Doug Gillespie, Gordon Hastie, Jonathan Gordon, Jamie Macaulay, Chloe Malinka, Mick Wu and Bernie McConnell

Sea Mammal Research Unit

Scottish Oceans Institute,

University of St Andrews, St Andrews, Fife, KY16 8LB, UK

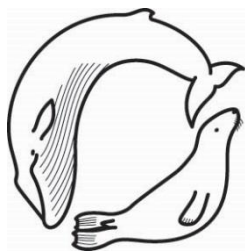

**Sea Mammal
Research
Unit**

Table of Contents

1.	Executive Summary.....	1
1.1.	Introduction.....	1
1.2.	Sensor Choice and Platform	2
1.3.	Field Trials	3
1.4.	PAM Results	3
1.5.	AAM Results.....	4
1.6.	Discussion – Remaining Work Before Progress to Phase 2.....	5
1.7.	Discussion – General Design Principles	5
1.8.	Discussion – Future Considerations	5
2.	Introduction	7
2.1.	Background and Policy Environment.....	7
2.2.	System Requirements	9
2.3.	Project Outputs and Tasks	11
3.	Sensor Choice and Platform Review	12
3.1.	Sensors: PAM.....	12
3.2.	Sensors: AAM.....	14
3.3.	Sensors: Video Surveillance	18
3.3.1.	Nacelle Mounted Video	18
3.3.2.	Foundation Mounted Video.....	19
3.4.	Platform Choice	19
3.5.	Recommendations for Sensor and Platform Choice	23
4.	Overview of Field Trials	24
4.1.	June 2015	24
4.2.	August 2015.....	24
4.2.1.	HiCUP Design	26
5.	Passive Acoustic Monitoring System Testing and Development	28
5.1.	Methods.....	29
5.1.1.	Hydrophone Cluster Design	29
5.1.2.	Tag Detection and Tracking.....	30
5.1.3.	Sound of Sleet Deployments	31
5.1.4.	Alignment and Calibration Trails	32
5.1.5.	Acoustic Data Analysis.....	33
5.2.	Results	34
5.2.1.	HiCUP Location	36
5.2.2.	Timing Accuracy.....	38
5.2.3.	Localisation Accuracy	40
5.2.3.1	Localising the Position of Broadcast Pings	40
5.2.4.	Fish Tag Detection Range	44
5.3.	Localisation Error Simulation	44

5.4.	Data Acquisition and Processing Development	48
5.4.1.	Click Timing Measurements	48
5.4.2.	Data Acquisition System	49
6.	Active Sonar System Testing and Development	51
6.1.	3D Marine Mammal Tracking using Multi-beam Sonar	51
6.1.1.	Perpendicular Orientation Technique	53
6.1.2.	Parallel Orientation Technique	56
6.2.	Development of Automated Marine Mammal Classifiers	62
6.3.	Porpoise Click Detection with the Active Sonar	67
6.4.	VEMCO Acoustic Tag Detection with Active Sonar	68
6.5.	Cowling Tests with Active Sonar	68
6.6.	Imaging Capabilities of Other Species with Active Sonar	69
6.7.	Integrating Tracking Sensors on Seabed Mounted Platforms	70
6.7.1.	Sonar HiCUP Deployment A – Imaging Marine Mammals in a Tidal Channel	70
6.7.2.	Sonar HiCUP Deployment B – Long Term Functionality	77
7.	Video System	80
8.	Discussion	81
8.1.	Passive Acoustic Monitoring (PAM)	81
8.2.	Active Acoustic Monitoring (AAM)	82
8.3.	Video Surveillance	83
8.4.	Proposed Tidal Turbine Site Deployment – MeyGen	83
8.4.1.	PAM	84
8.4.1.1.	Installation	86
8.4.1.2.	Shore Side Processing	86
8.4.1.3.	Data Volume and Management Strategy	87
8.4.1.4.	Alarms and SCADA Interface	88
8.4.2.	Acoustic Tags	88
8.4.3.	AAM	89
8.4.3.1.	Shore Side Data Processing, Analysis and Storage	91
8.4.4.	Video	92
8.5.	Generic Application Principles	93
8.6.	Data Analysis Requirements in Relation to Final Deployment	94
9.	Literature Cited	96
10.	Acknowledgements	99
11.	Glossary	100
12.	Appendix A: Development of New PAM Timing Algorithms	102
13.	Appendix B: Seal Depth Calculation from Vertically Offset Multi-beam Sonars	106

Executive Summary Scottish Government Demonstration Strategy: Trialling Methods for Tracking the Fine Scale Underwater Movements of Marine Mammals in Areas of Marine Renewable Energy Development

Carol Sparling, Doug Gillespie, Gordon Hastie, Jonathan Gordon, Jamie Macaulay,
Chloe Malinka, Mick Wu and Bernie McConnell

1. Executive Summary

1.1. Introduction

Sectoral Marine Planning and related strategic assessment processes have identified a need to evaluate the potential interactions between marine renewable energy developments and marine wildlife as a matter of priority. Despite significant progress in the industry over recent years, there remains a great deal of uncertainty about the risk that tidal turbines in particular pose to marine mammals.

There is, therefore, a clear need to improve the understanding of how animals perceive and respond to devices. The Demonstration Strategy is a key component of the Scottish Government's 'Survey, Deploy and Monitor' (SDM) policy approach to reducing the environmental uncertainty currently inherent in the licensing of renewable energy developments in Scottish waters. It will allow the monitoring of early renewable projects to investigate such interactions. It is crucial that appropriate and achievable techniques are in place for these early projects to collect the data required to characterise the true nature of any impacts – and that data are collected and analysed in such a way as to inform the development of tools that help assess future risk (e.g. collision risk models).

Suitable instrumentation and methodologies are generally lacking and those that are available for the detection and tracking of marine mammals require a degree of development before it is possible to be confident that they can be successfully deployed in conjunction with tidal energy projects. In order to study the fine scale movements of animals close to a tidal energy device and potentially monitor collisions, monitoring systems are required with the ability to track animals with a high spatial and temporal resolution and over a range of several tens of metres from the turbine for a period of several months.

This report details the progress of Phase 1 of the Scottish Government Demonstration Strategy (SGDS) project: Developing and testing methodologies for measuring fine scale marine mammal movements around tidal energy devices.

The approach considered here comprises three sensor systems: Passive Acoustic Monitoring (PAM), Active Acoustic Monitoring (AAM) and Video Surveillance. Whilst each of these systems have been used to study marine animal movements, their combined application in a high tidal energy environment requires development and testing.

1.2. Sensor Choice and Platform

Out of a range of potential platform options reviewed, the recommended approach is to install monitoring equipment which is integrated with the turbine's power and data transfer systems. As it is necessary to have a prolonged period of near continuous monitoring to get sufficient sample sizes and statistical power to make robust inferences from the early demonstration projects, it is recommended that a cabled system would provide the best chance of implementing an optimal monitoring solution capable of meeting the objectives of the project.

After evaluation of the available sensor types, the preferred solutions for this application are the Tritech Gemini multi-beam system for AAM and a multi-hydrophone volumetric array using a networked industrial data acquisition system for the PAM.

In January 2016, a video engineer was commissioned to provide the design for a 180 degree, low light camera with ultraviolet LED bio-fouling control. It is planned that two such cameras will be deployed on the foundation – fore and aft of the turbine. These data will be streamed ashore by cable.

To detect seals with the PAM array it is recommended that VEMCO acoustic pinger tags should be fitted to a sample of local harbour seals (*Phoca vitulina*). The VEMCO V16P-6H acoustic pinger was trialled with successful results. It has a longevity of 100 days with a 1-2 second interval between pulses. Harbour seals should ideally be tagged shortly prior to the deployment of the tidal turbines to provide a period of pre-installation, baseline data. However, the timing of tagging is constrained by the timing of the annual moult, which occurs in August. The pinger transmits at 83 kHz. While the majority of the sound will be above the hearing threshold of harbour seals, it is possible the pulse onset may be perceived. Although

unlikely that prey species will be able to hear them, it is possible that the tags will be audible to some dolphins and porpoises.

1.3. Field Trials

Once the preferred system configuration had been decided, there was a need for a series of development tasks and field tests. Field tests were carried out on the west coast of Scotland in summer 2015 with the following primary objectives.

- a. Test deployment and operation of two domed Tetrahedral Hydrophone Clusters (THCs) on fixed seabed mounted platforms for a period of weeks;
- b. Evaluation of dome shape and hydrophone spacing;
- c. Investigation of detection probability and localisation accuracy of the hydrophone clusters;
- d. Investigation of the ability to detect and track VEMCO acoustic pinger tags (these tags can be fitted to seals so they could be detected and tracked with the PAM);
- e. Test deployment and operation of twin Gemini sonars on a fixed seabed mounted platform for a period of weeks;
- f. Investigation of the imaging capabilities of the sonars from a seabed mounted perspective;
- g. Collection of data to validate the active sonar marine mammal classification algorithms;
- h. Collection of data to develop and validate 3D marine mammal tracking ability using the dual sonar configuration.

1.4. PAM Results

Field trials demonstrated that the THCs were reliable and capable of detecting harbour porpoise (*Phocoena phocoena*) and bottlenose dolphin (*Tursiops truncatus*) clicks. Location accuracy was investigated using trials with an artificial porpoise sound and using simulations. Trials also demonstrated that the spherical cluster design had better timing accuracy than the cylindrical design which is likely to be a result of a combination of the different shape of the cowling and also in the spacing of the hydrophones – the spherical clusters had a narrower hydrophone cluster spacing meaning that the signals were less distorted by echoes than the more widely spaced hydrophones in the cylindrical cluster. Changes in timing accuracy affect the accuracy at which sounds can be localised, but do not affect detection range.

The simulations for a system consisting of three clusters in a triangular configuration around a turbine structure indicate a localisation accuracy of < 3 m; depth < 0.7 m and angle < 0.5 degrees at 25 m from the hydrophones.

While timing accuracy of the VEMCO tag pulses is not as good as it is for porpoise clicks ($\pm 7.5 \mu\text{s}$), this has little impact on localisation accuracy at short ranges.

The PAMGuard software was modified to allow detection of VEMCO acoustic tags. Work has also gone into further developing a data acquisition system in order to make it stable when sharing a network connection with other devices. Further work is required to increase the number of channels from 8 to 12.

1.5. AAM Results

This project has developed and tested a technique to track marine mammals in 3D in a tidally energetic environment using two multi-beam sonars. Two different configurations were tested for this and it was concluded that an overlapping parallel horizontal orientation provided the best results. By measuring the ratio of the sonar intensity of a target imaged simultaneously on two sonars arranged in this way, the depth of the animal was calculated. The error in depth estimated in this way is approximately 1.5 m (although this may be less when the sonars are mounted on a static platform).

An efficient algorithm was developed to classify marine mammals in multi-beam sonar data, reducing the high false positive rate reported in previous studies. Cross-validation of the resulting algorithm estimated a cross validation error of 6%. All confirmed seals were correctly classified using the algorithm, while only 8% of non-seal targets were classified as seals. If this result holds with future datasets, the analytical approach will be an effective means of detecting and classifying harbour seals. At present, the effectiveness of these algorithms for classifying other species is unknown; however, it is anticipated that it is likely to be effective for similar sized marine mammals (e.g. grey seals (*Halichoerus grypus*), harbour porpoises, dolphins).

The bottom mounted configuration, likely to be used in the turbine site deployment has also been successfully tested in a tidally energetic environment. This has demonstrated that tracking and detection algorithms can still detect marine mammals against a backdrop of additional background noise and surface clutter (in sea states up to Beaufort 2). However, it should be highlighted that the effects on detection and tracking capabilities of sea states above this are largely unknown at present.

1.6. Discussion – Remaining Work Before Progress to Phase 2

Whilst considerable progress has been made during this project, there remains some development work required before progressing to Phase 2 of the Demonstration Strategy, which is physical deployment at the MeyGen site in association with the Atlantis AR1500 turbine as part of MeyGen's Phase 1a. This includes a series of hardware/installation related decisions and tasks: e.g. final design decisions on THCs, decisions about physical mounting and fixing methods, and agreement on a final design for the AAM seabed platform. Furthermore, there are a number of software developments required, for example to integrate the sonar detection algorithms into the existing sonar software to reduce post hoc analysis.

1.7. Discussion – General Design Principles

While the focus was to develop systems which can be integrated into a specific turbine (AR1500), most of the basic design principles are applicable to the use of these sensors in other situations. The principal areas of investigation and agreement for any monitoring programme associated with a tidal turbine are:

- a. Power and communication availability – both AAM and the PAM systems required several watts of power and produce high volumes of data;
- b. Physical locations for mounting equipment – the preferred position for AAM is at some distance away to ensure full coverage on the rotors whereas an evenly spaced array, close to the turbine is preferred for the PAM. Video is limited by visibility but there is likely to be a trade-off between coverage and range;
- c. Potential for interference or cross talk between different monitoring equipment. For example, Acoustic Doppler Current Profilers (ADCPs) (which are a necessary feature of tidal turbine arrays) and other acoustic monitoring emit high frequency signals which may interfere with the active and passive detectors. Synchronisation can be achieved to reduce interference but these signals could also potentially affect the behaviour of animals around a device.

1.8. Discussion – Future Considerations

Consideration must be given to the analytical techniques that will be required to use the data resulting from this system to parameterise collision risk models. It is likely that data will be sparse due to the expected low encounter rate of local seals and porpoises. It is also likely that data about individual encounters will be fragmented.

It would be useful, therefore, to consider the construction of a Bayesian movement model that could incorporate these three disparate data sets (with uncertainty) to predict a best estimate (with uncertainty) of the 3D trajectory of animals in the vicinity of a turbine blade. This will provide a better ability to make inferences about the behaviour of animals around the turbine, and to determine whether collisions are taking place.

Similarly, there will be a level of uncertainty in how well any of these techniques detect the outcome of an encounter – whether there was successful evasion or a turbine impact. An uninterrupted vocal sequence of clicks continuing after a close encounter with the rotor area would suggest that a porpoise has evaded impact. Similarly if the track data suggests an interrupted movement path after travelling through the rotor sweep this would suggest a lack of impact. Again, there is a need to combine data sets (and perhaps others such as strain gauge information on the turbines) in a Bayesian model to estimate the most likely outcome of a close encounter.

2. Introduction

2.1. Background and Policy Environment

The Scottish Government has set a target of meeting the equivalent of 100% of Scottish energy demand from renewable energy sources by 2020. The Scottish Government's 2020 Route map for Renewable Energy in Scotland (Scottish Government, 2011, 2012), outlined that offshore and marine energy generation will be an important part of meeting this demand. Scotland's wave and tidal energy resource is almost unparalleled, representing a quarter of Europe's tidal stream and 10% of its wave energy potential. The commercial exploitation of these resources is still at an early stage and learning from prototype and pre-commercial demonstration projects needs to be maximised.

The Scottish Government has a duty to ensure that the industry develops sustainably, with minimal impact on the marine environment. Successive Strategic Environmental Assessments (SEA) for wave and tidal renewable energy generation in Scottish waters (Faber, Maunsell & Metoc, 2007) and those undertaken for the Draft Sectoral Marine Plans for Wave and Tidal Energy (Scottish Government, 2013) identified a need to evaluate the potential interactions between marine renewables and marine wildlife as a matter of priority. Despite significant progress in the industry over recent years, there remains a great deal of uncertainty about the risk that tidal turbines in particular pose to marine mammals. The risk of direct interactions between turbines and marine mammals has been identified in several recent reviews as being a priority issue (Sparling *et al.*, 2013; ORJIP, 2016). In order for the Scottish Government to provide legal consent to future commercial scale tidal projects, there needs to be an understanding of this risk. Currently, the Habitats Regulations Assessments (HRA) and the Habitats Directive require a degree of certainty that a proposed plan or development will not have a significant impact on marine mammal populations before the projects can be consented.

Any uncertainty in terms of risk of impact may lead to lack of future consenting and ultimately curtail the development of the industry. This uncertainty, therefore, translates into increased regulatory constraint and inevitably increased financial cost and investor uncertainty. Such constraints and uncertainties have the potential to limit the development of marine renewable energy solutions, or inhibit the large-scale uptake of the technology at a level that will significantly contribute to meeting future UK energy demand.

To address this, there is a clear need to improve the understanding of how animals perceive and respond to tidal devices. The Scottish Government has put in place a 'Survey, Deploy and Monitor' (SDM) policy which aims to facilitate a risk-based approach for new renewable technology under these uncertainties. In practical terms, this policy will allow the monitoring of early renewable projects to investigate such interactions. It is crucial that appropriate and achievable monitoring techniques are in place for these early projects to collect the data required to characterise the true nature of any impacts – and that data are collected and analysed in such a way as to inform the development of tools to help assess future risk (e.g. collision risk models).

In addition, it is likely that licence conditions (Marine Licences and Section 36 consents under the Electricity Act (1989)) of most early array projects will contain the need for similar monitoring and, therefore, there is much value in developing cost effective ways of achieving this, without putting too onerous a burden on the fledgling tidal industry.

According to the Offshore Renewables Joint Industry Programme (ORJIP) Ocean Energy Forward look document (ORJIP, 2016), collision risk is a priority for the industry and strategic monitoring studies around single turbines and first arrays have the potential to provide evidence to reduce uncertainty around collision risk, evasion and avoidance behaviour. Data are urgently required which will help determine the likelihood/probability of collision and, in particular, close range encounter rates around devices and evidence of evasive abilities.

Furthermore, suitable instrumentation and methodologies are generally lacking and those that are available for the detection and tracking of marine mammals require a degree of development before they can be successfully deployed in conjunction with tidal energy projects (McConnell *et al.*, 2013).

2.2. System Requirements

In order to study the fine scale movements of animals close to a tidal energy device, and potentially monitor collisions, monitoring systems are required with the ability to track animals with:

1. High spatial resolution (approximately 1m).
2. Fine temporal resolution (approximately 1s)
3. Over a range of several tens of metres from the turbine.

Since encounter rates are likely to be relatively low (Thompson *et al.*, 2015), the system will need to operate in a stable manner for several months in order to acquire useful amounts of data (multiple encounters with different animals and species) to have the necessary power to make inferences and general conclusions about animal behaviour around tidal turbines and to refine current estimates of collision risk.

There are two principal elements that data are required to inform. The first is the empirical near field encounter rate close to operating devices and the second is the measurement of marine mammals' ability to avoid turbines.

Encounter rates can be compared to the predicted encounter or collision rate estimates carried out during the licencing of the project. Encounter rate modelling carried out for the MeyGen project predicted between 6.5 and 7.8 harbour seal 'encounters' per turbine per year depending on the density estimate used (SRSL, 2012). An encounter was defined as the rate of encounters between an animal and the volume of the swept area of the rotors. Equivalent predictions for harbour porpoises were between 4.9 and 9.4 depending on whether a mean estimate or upper confidence limit of the density estimate was used. These numbers are low but scaling them up to the volume covered by the monitoring system could potentially allow the determination of how many detections to expect. The encounter rate can then be monitored on a regular basis to assess how empirical rates compare to those predicted.

However, an on-going re-assessment of collision risk for the project provided estimated collision rates of between 13 and 389 per turbine per year for harbour seals depending on which available mean density estimate was adopted (Band *et al.* in review), and if the wide confidence intervals around these density estimates are considered, the potential range is even greater. It is clear that there is some uncertainty regarding the likely encounter rates and it will be important to regularly review detection rates and update predictions of risk accordingly.

The ability to measure avoidance or evasion behaviour will depend entirely on the encounter rate and as noted above, there is uncertainty about what this might be at the site. Therefore, it is difficult to define an exact required monitoring period, however, it is likely that an extended monitoring period of at least twelve months will be required.

The primary target species around Scotland in areas of tidal energy resource are harbour porpoises and harbour seals. Together these are the species of most concern due to the high potential for encounter for harbour porpoises (Wilson *et al.*, 2007) and the current unfavourable status of the Scottish harbour seal population (SCOS, 2015). These target species are also representative of the two primary 'types' i.e. an echo-locating cetacean species that can be detected acoustically and a seal species which do not echolocate and can only be detected by active or visual means.

The approach considered here comprises three sensor systems: Passive Acoustic Monitoring (PAM), Active Acoustic Monitoring (AAM) and Video Surveillance. Whilst each of these systems have been used to study marine animal movements, their combined application in a high tidal energy environment requires development and testing.

This report details the progress of Phase 1 of the Scottish Government Demonstration Strategy (SGDS) project: Developing and testing methodologies for measuring fine scale marine mammal movements around tidal energy devices.

To achieve its objectives, the project was split into a number of distinct tasks:

- Sensor and platform choice;
- Identification of development work required to provide a system to meet these requirements;
- Hardware and software development work;
- Field tests;
- Scoping and planning for Phase 2 of the project – the deployment of the system at a tidal energy development.

2.3. Project Outputs and Tasks

The deliverables from Phase 1 of the SGDS project are as follows:

1. Further development of suitable active and passive sonar systems for deployment in a high tidal energy site. This should involve some initial experimental field trials to test the capabilities of the systems in a high tidal energy environment, resulting in,
2. A technical specification for an AAM, PAM and video monitoring system that has the capacity to track marine mammals around tidal turbines including both hardware and software, and including consideration of positioning and mounting.

The remainder of this report is split into a number of sections.

Section 3 is a review of the available sensor systems and options for deployment platforms (e.g. autonomous battery powered system or cabled to shore). The section concludes with the recommendations for PAM, AAM and video surveillance systems and configurations, as well as the preferred option for deployment platform.

The subsequent sections (Sections 4 to 7) detail the development and testing work that was undertaken for each sensor type. These all follow a similar format where the development objectives are described, followed by accounts of the work carried out to meet those objectives, both in the laboratory and in the field, and both in terms of hardware and software development. Since the location and methodology of the AAM and PAM field trials overlapped, an overview of the field trials is provided in a separate section to avoid repetition.

Section 8 provides a discussion and an overview of the development work still remaining before the deployment of the sensors integrated with a tidal turbine can take place in addition to providing an overview of the general principles to be considered for the implementation of this type of monitoring on other projects.

3. Sensor Choice and Platform Review

At the outset of this project, it was identified that there were a number of available options for sensor choice/configuration and deployment platform. A review of these options was carried out as the first task in this project. A separate report was completed which described the available options for both sensor choice and deployment options, detailed the evaluation process and provided recommendations for progression (McConnell *et al.*, 2013).

3.1. Sensors: PAM

Both echolocation clicks and whistles can be localised by measuring the time of arrival differences of the sounds on multiple hydrophones. A closely spaced cluster of four hydrophones arranged in a tetrahedral pattern can measure bearings to a sound source, but will not provide any range information. However, if the hydrophones are spaced further apart they can, in principle, track animals in three dimensions. In practice more than four hydrophones are required for accurate tracking, with tracking accuracy falling off rapidly beyond the array boundaries. As a rule of thumb, reasonable accuracy can be obtained out to about three times the array dimension, with very poor accuracy beyond ten times the array dimension. Operation of volumetric arrays does of course require the sounds to be detected on multiple hydrophones and the different sounds on the different hydrophones to be accurately matched. This can be problematic due to the highly directional nature of echolocation clicks which effectively makes it impossible for an animal such as a porpoise to be pointing towards multiple widely spaced hydrophones at the same time. Previous research has shown, however, that animals can successfully be detected on multiple hydrophones tens of metres apart (Macaulay *et al.*, 2015).

Harbour porpoise vocalise at a frequency of around 130 kHz, which requires specialist ultrasonic sampling equipment, typically sampling each hydrophone on the system at a rate of at least 500 kHz. Uncompressed 16 bit data from a single hydrophone, therefore, requires 86 GBs of storage per day. A four channel system would, therefore, require 345 GBs and an eight channel system nearly 0.7 TBs of storage per day. While there are an increasing number of commercially available autonomous recorders on the market (Sousa-Lima *et al.*, 2013) none of these are capable of multi-channel high frequency recording and, even if they were, they are unable to store the data for more than a day or two.

For this application a Commercial DAQ Chassis based system was selected – with up to ten hydrophones connected via custom built preamplifiers to a National

Instruments chassis (e.g. NI cDAQ-9188 or cRio 9067). Simultaneous sampling occurs across all channels making it ideal for accurate timing measurement. The system can be installed as either stand-alone, or connected via high speed Ethernet to shore. When connected to shore, processing takes place in real time on a standard PC, which can detect and localise both clicks and whistles in near real time and also archive either all, or a selection of, the raw audio data for later analysis.

Power consumption of the system (including the NI chassis and associated preamplifiers) is approximately 10W. A 100Ah battery would, therefore, run the system for five days. One of the FLOWBEC (Williamson *et al.*, 2015) battery banks with an 1100Ah capacity could potentially run the system for 50 days.

When running stand-alone on an autonomous platform, the duration of deployments is limited primarily by data storage capacity. With lossless data compression (Johnson, Partan, and Hurst, 2013) a four TB hard drive would provide storage for 20 days of data for an eight channel hydrophone system. When connected via Ethernet cable to shore, deployment duration is unlimited. However, a reasonably high bandwidth (minimum 100 Mbps) Ethernet connection is required.

The cabled system can process data from up to ten independent hydrophones simultaneously and has the great advantage of providing high resolution real time data to operators on shore. Power is supplied from shore and is, therefore, unlimited as is storage since hard drives can easily be swapped by on shore operators. The system is reliant on the availability of a shore cable providing power and high speed fibre capable of delivering a data rate of 100Mbps, though this is not a problem using standard fibre LAN components if a dedicated fibre can be made available for PAM data only. Shore side processing is accomplished using the PAMGuard software (Gillespie *et al.*, 2008; www.PAMGuard.org) which is fully open source.

This system has been installed in a 'cabled to shore' format on the Tidal Energy Ltd (TEL) turbine recently deployed in Ramsey Sound. The stand-alone system has been developed under a Natural Environment Research Council (NERC) Knowledge Exchange grant and trials of a free floating system, in which the data acquisition chassis was housed in a floating barrel with an eight hydrophone tracking array suspended beneath it, were recently successfully completed in Kyle Rhea Scotland and the West Anglesey Demonstration zone in Wales (Macaulay *et al.*, 2015).

Whether operating in stand-alone or cabled mode, data processing is conducted using the PAMGuard software which can search simultaneously for both clicks and whistles. A modern PC is capable of searching each data channel individually for

sounds of interest, so hydrophones can be installed in almost any configuration. Three dimensional localisation is available for clicks which will be implemented for whistles in the future.

3.2. Sensors: AAM

Previous work through a Department of Energy and Climate Change (DECC) funded project reviewed a wide range of active sonar systems, critically testing and validating a selection of systems that could potentially be used as marine mammal tracking systems for the tidal stream energy industry (Hastie, 2012). The results suggest that one system (Tritech Gemini) has the potential to reliably detect and track small marine mammals around tidal stream energy devices at relatively high resolution without causing overt behavioural responses by animals. The Gemini has proved to be effective at detecting marine mammal species including grey and harbour seals, harbour porpoises, and bottlenose dolphins. To date, this remains the only system that has been fully validated with marine mammals and has been shown not to cause overt behavioural responses by marine mammals (Hastie, 2012). Although there are clearly a number of other sonar systems capable of detecting marine mammals (with other devices, such as the Imagenex multi-beam used in the FLOWBEC system, showing promise for the detection of marine mammal targets in tidally energetic environments (Williamson, 2015)), at this stage it would be relatively high risk for the project to consider using these prior to further detection capability and behavioural response tests; it is therefore recommended that the Tritech Gemini be used for this application.

Previous work testing the detection capabilities of the Gemini (Hastie, 2012) was carried out in low energy tidal areas and the imaging capabilities of this system in tidally energetic areas was not validated. The use of multi-beam sonar in tidal environments can be limited by inherent problems associated with acoustics in these conditions; it is known that the highly heterogeneous water characteristics near the surface or wind generated clutter are likely to have significant impacts on the imaging capabilities of sonar. It is possible that animals will be effectively masked by acoustic clutter under certain conditions, therefore, some testing is required in a seabed mounted configuration (see Section 6.7.1).

The temporal resolution of the Gemini is approximately 10Hz when imaging up to ranges of 60 metres; the angular range resolution is 0.5° and the range resolution is 0.8 cm. The horizontal and vertical swathe widths of the Gemini are 120° and 20° respectively. Effective automated detection ranges measured in previous work were ~36 metres (Hastie, 2012). It would, therefore, seem most efficient to mount the

sonar at a location approximately 30-36 metres from the rotors. Given this, the most efficient option for monitoring the rotors would be a remote platform located at this distance from the side of the turbine.

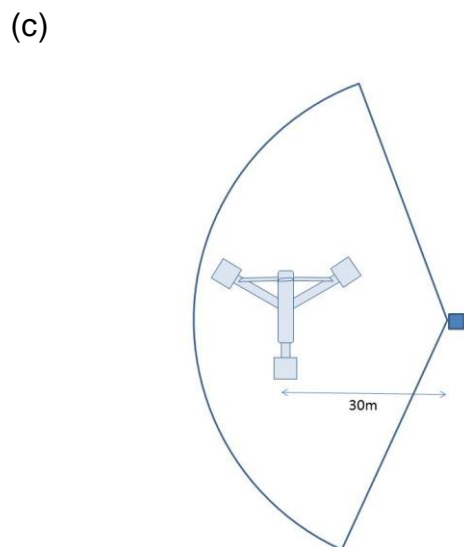
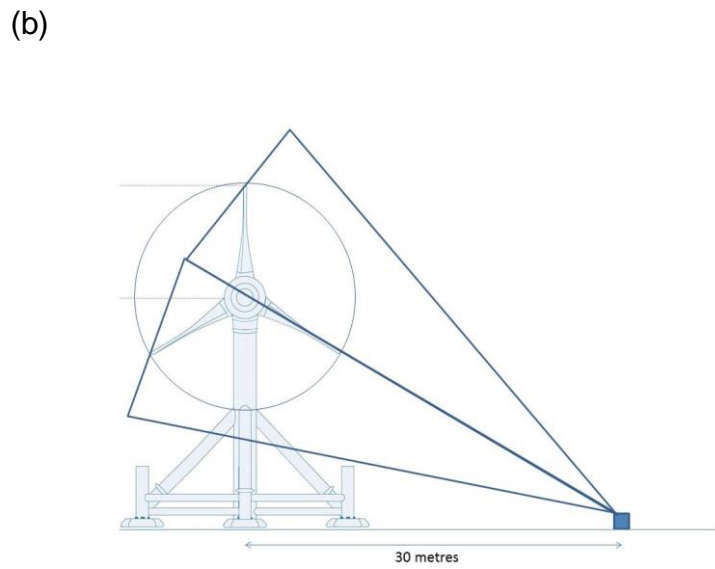
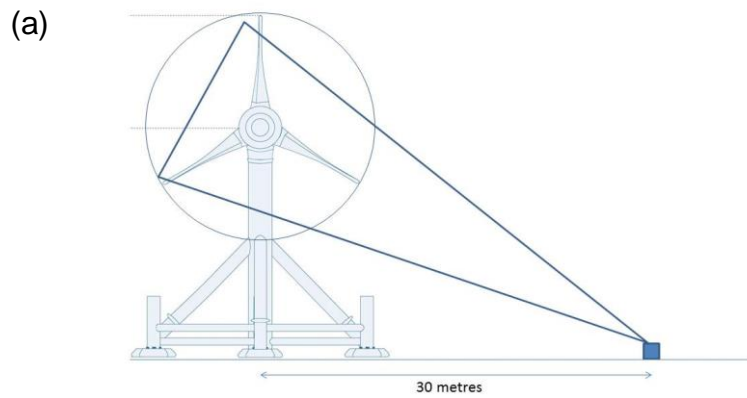

Figure 1: Potential deployment configurations of multi-beam active sonar deployed on a remote platform to the side of an 18 m diameter rotor turbine. The figure illustrates the approximate rotor coverage using (a) single, and (b) dual sonar heads, and (c) shows a plan view of the approximate horizontal coverage. These configurations are based on the dimensions of the proposed devices for the MeyGen site.

Given the vertical swathe of the multi-beam is 20°, the effective vertical coverage of the rotors at a range of 30 metres from the turbine would be ~11 metres; this clearly limits the monitoring capabilities for turbines with larger rotors. However, full rotor coverage for larger turbines could be achieved using two sonar heads on a remote platform (Figure 1), although this would need more power.

Based on these general monitoring approaches, two systems are described (each with one or two sonar head configurations) which could be used for long term sonar monitoring:

System 1: Multi-Beam Sonar with Fibre Cable to Turbine/Shore

As described above, the most efficient location for a sonar monitoring platform would be located ~30 metres to the side of the turbine with a single or dual (depending on rotor diameter) multi-beam sonar orientated to cover the rotors.

Power (24V) for the platform would be supplied via an umbilical from the turbine. As raw data can effectively be streamed ashore using the same umbilical, no on board detection or tracking processing would take place and all raw sonar data transfer would be direct via a high speed optical fibre to a PC onshore; processing and data storage would also take place onshore. The system is reliant on the availability of an umbilical providing suitable power and high speed fibre capable of delivering a data rate of a minimum of 100 Mbps; in practice data rates are markedly lower than this but it is not anticipated that using standard fibre LAN components would be problematic.

The platform for the sonar mounting could be a relatively small structure (similar to an ADCP mount) but would require appropriate ballast for the tidal conditions.

System 2: Multi-Beam Sonar on Autonomous Platform (e.g. FLOWBEC)

In an autonomous configuration, power for the platform would be supplied from a bank of batteries on the platform. This is the approach taken by the FLOWBEC platform which has a total of ~4,400Ah of battery capacity at 12V on it. Seventy five percent of this (assuming 25% used to power an accompanying PAM system), under full discharge would potentially provide power for a single or dual sonar system for a total of 38 and 21 days respectively. If anything less than full battery discharge was required (e.g. to prolong battery life) then these times would reduce accordingly.

As raw sonar data cannot be streamed to shore in this configuration with a battery powered platform such FLOWBEC, on board detection or tracking processing would have to take place on an integrated low power PC with data storage on an external 4TB HDD. Based on storing all raw data, this approach would allow a total of 36 and 18 days monitoring for a single and dual sonar system respectively. Alternatively, by running the on-board detection algorithms and only saving data associated with target detections, the storage requirement could be markedly reduced. For example, based on a detection of three targets per hour, a total of 164 and 82 days monitoring would be possible for the single and dual sonar systems respectively (although power would become limiting before this).

3.3. Sensors: Video Surveillance

Video surveillance can be used to detect a subset of any animal encounters, although it is restricted to periods of good visibility. Video during such windows of daylight and good visibility may determine and characterise those PAM and AAM track segments that could potentially have resulted in a collision. Thus video will be continuously streamed (estimate of 16 Mbps per camera) ashore and archived on hard drive. These data will be inspected when there is indication from the PAM or AAM systems that there has been likely animal encounter. It is also proposed, however, that random segments (say one hour duration each day) should be inspected to ensure that there are no video-detected animal encounters that were not detected by PAM and/or AAM.

It is acknowledged that video surveillance and thus the ability to interpret the outcome of animal encounters is not available at night or in poor underwater visibility.

The siting and design of any video surveillance system depends on the turbine and foundation design. Here, two system configurations for a specific turbine (Atlantis AR1500 with bespoke foundation – planned for deployment in 2016 by MeyGen) are considered:

3.3.1. Nacelle Mounted Video

MeyGen have specified that there will be a single camera mounted on the nacelle (casing) whose primary purpose is to provide visual information on turbine operation. Its field and direction of view can be adjusted shore side by a remotely controlled zoom, pan and tilt mechanism. It will be fitted with a mechanical scrubber to remove

any optical port bio-fouling. However, at any one time it will be only able to view a small part of the rotors (less than one third of total arc of rotation). Therefore, the nacelle mounted video is not ideal for the monitoring requirements of this project.

3.3.2. Foundation Mounted Video

The preferred option is to mount a total of two wide-angle video cameras on two of the foundation legs. They would be positioned just inboard of the hydrophone clusters – and would share the cabling conduit to the dry junction box on the foundation tower. Being wide-angle, these video cameras will capture more than the turbine arc, enabling near misses to be positively detected where visibility allows.

3.4. Platform Choice

The practical difficulties of installing complex monitoring systems in a highly energetic marine environment should not be underestimated and while attempts were made to separate out the “Sensors” from the “Platforms” it was not possible to finalise one without consideration of the other. AAM, PAM and video all generate considerable quantities of data (many GBs per day) which must either be stored or processed on the device or transmitted to shore, and they all require power.

The power required to operate the sensors and the storage required for the data they generate restrict the lifetime of autonomous battery powered platforms. On the other hand, the infrastructure costs for cabling these devices to shore are not insignificant. Thus there is not a “one size fits all” monitoring solution, but a number of options for both the platform/installation method and for the sensor technology to choose from for a particular application.

In order to inform the evaluation of the available deployment options, a number of key drivers were identified in discussion with the project steering group. These are outlined in Table 1.

Table 1

Key drivers used to evaluate deployment options.

Driver	Description
Data latency	The time between data collection and having the data 'in hand' to examine. How 'real time' is the monitoring?
Suitability for preferred sensors	Can the power and data requirements of selected sensor (PAM and AAM and video) technology be met using the proposed deployment option?
Ability to alter monitoring settings	Can the user communicate with the sensors <i>in situ</i> to change settings if required?
Duration of deployment	How long can individual monitoring periods be before power availability or data storage limits continuing data collection?
Generality	How easily the technology or design can be applied to a range of sites and tidal turbine technologies.
Scalability	How easily the technology can be scaled up to monitor an array of turbines over extended time scales.
Technology readiness/availability	Is the deployment option already available 'off the shelf'? If not, what development work is required? What other resources are required?
Lack of impact	Is the methodology proven not to influence the behaviour of marine mammals?
Availability for use in this project	If already developed, is the option available for use in the current timelines of the project?
Cost - Development	What is the cost involved in developing the deployment option to meet the requirements of this project?
Cost – Running	What are the costs involved in ongoing monitoring using a particular deployment option?
Risks/Intervention requirements	What are the risks involved in the particular deployment option? How easily can they be mitigated? What requirements are there to access underwater components using divers/ROVs etc.?
Redundancy	What happens when things go wrong? How much redundancy can be built into the system to mitigate against technical problems?

A number of deployment options were identified and reviewed based on these criteria. From this review, two main options were identified:

1. To cable the sensors to shore via the turbine with power and data transfer abilities supplied by the turbine infrastructure, or
2. To deploy on an autonomous, battery-powered system.

Table 2 provides a summary of the evaluation of these two options against the drivers identified above while Table 3 provides a summary of the advantages and disadvantages of each system.

Table 2

Evaluation of each deployment option against the key drivers.

Driver	PAM and AAM on turbine or remote structure(s) - power & comms. via cable from turbine	Using a self-contained, autonomous platform such as FLOWBEC as remote structure for PAM and AAM - battery power and on board data storage
Data latency	Low	High
Suitability for preferred sensors	High	Medium – suboptimal spacing for PAM clusters
Ability to alter monitoring settings	High	Low
Duration of deployment	Not limited by power or comms	Short (~20 days - PAM data storage limits duration)
Generality	Medium	High
Scalability	Medium	Medium
Technology readiness/availability	Medium	High
Availability for use in this project	Dependent on turbine manufacturers and operators	Dependent on FLOWBEC frame availability
Cost - Development	~£20K	~£10K
Running cost of 1 year of deployment	~£45K	18x 20d deployments = ~£340K (from previous deployments at EMEC)
Risks/intervention requirements	Risks associated with cable connection. Requirement for ROV or diver for electrical connection to turbine. Potential risk to turbine from umbilical. Complexity of connections and integration	Deployed and retrieved from boat. ROV required for retrieval. Little risk to turbine. Additional H&S risk of multiple boat operations.
Redundancy and maintenance	Can build in redundancy and system can be accessed remotely to troubleshoot, although heavy reliance on cable and connectors – difficult to access / replace hardware	Little redundancy possible on single deployment. System has to be recovered to alter settings. But regularly maintained so there is opportunity to replace or repair hardware between deployments.

Table 3

Summary of the main advantages and disadvantages of the two main deployment options.

Option	Advantages	Disadvantages
PAM and AAM integrated with turbine (either on remote structure or on turbine structure itself but power & comms via cable from turbine)	<ul style="list-style-type: none"> • Extended, continuous deployment • Risk of data loss low • Real time data inspection (reduced risk of data loss and ability to 'tweak' settings) • Can trigger video data collection • Smaller seabed deployment footprint possible 	<ul style="list-style-type: none"> • Expense of cable system • Difficulty/cost of connection • Failure of umbilical would result in loss of monitoring • H&S implications of underwater connections – ROVs or divers • Dependent on cooperation (and funding) with turbine manufacturers/operators • Not field tested • Cannot collect baseline data
Using FLOWBEC as remote structure for PAM and AAM- battery power and on board data storage	<ul style="list-style-type: none"> • Can be deployed anywhere • Independent of turbine design • Field tested and reliable • Baseline data collection possible • Deployment and retrieval relatively low risk to turbine • Repairs/replacements possible between deployments 	<ul style="list-style-type: none"> • Only short deployments possible – system power and data limited • High cost of multiple deployments • Cannot check data/tweak settings during deployment so if there is a problem, data will be lost • Cannot trigger other monitoring systems in real time • Requirement for adaptation of existing platform to accommodate PAM array and integrate with existing sensors • Dependent on availability of FLOWBEC

3.5. Recommendations for Sensor and Platform Choice

After evaluation of the available sensor types, the preferred solutions for this application are the Gemini Tritech multi-beam system for the AAM and a multi hydrophone volumetric array based on the NI-chassis type system for the PAM. Although the choice of preferred sensor types are somewhat independent of the deployment platforms under consideration, it is impossible to finalise one without consideration of the other. While both the preferred PAM and AAM sensor systems can run on autonomous platforms using battery power and local data storage, the deployment duration will be limited. If the preferred PAM system is deployed then duration is ultimately limited by the data storage capabilities (20 days with 4TB on-board storage). A single multi-beam would run for approximately 38 days using three quarters of the battery power capacity available on the FLOWBEC frame (assuming three banks used to power the multi-beam and one bank to power the PAM), however, as two multi-beam units would be required to image turbine rotors of 18 m diameter, this would reduce deployment period to 21 days.

Due to the likely relatively low encounter rate of marine mammals with turbines, and the need for a prolonged period of near continuous monitoring to get sufficient sample sizes and statistical power to make robust inferences from the early demonstration projects, it is recommended that a cabled system would provide the best chance of implementing an optimal monitoring solution capable of meeting the project objectives. Early discussions with turbine engineers suggested that this was a practical option and the development and maintenance costs involved are below those estimated for regular retrieval and deployment visits for an autonomous platform.

The outcome of this review was discussed by the Project Steering Group at a meeting in September 2014, and based on input from MeyGen confirming that the sensor systems could be cabled and interfaced with the AR1500 turbine and that the alternative turbine design (Andritz Hydro Hammerfest) lacked suitable power and data communications bandwidth, the decision was made to develop an integrated cabled monitoring solution with the AR 1500 Atlantis turbine.

4. Overview of Field Trials

There were two separate sets of field trials carried out as part of the development programme to meet the objectives listed in the subsequent sections. These were carried out in June and August 2015 on the west coast of Scotland in the Kyle of Lochalsh/Kyle Rhea and the Sound of Sleat area. Further details of each of these field trials are provided below.

4.1. June 2015

Trials of the PAM and AAM systems under development were conducted in waters between the Isle of Skye and the mainland, between 7 and 12 June 2015. The trials had the following aims:

- a) Conduct preliminary tests of PAM system performance;
- b) Assess the ability of a dual AAM system to measure the depth of seals from the relative acoustic intensities on different AAM systems;
- c) Conduct a fine scale site survey of possible mooring sites in the upper Sound of Sleat in preparation for more extensive trials of both the PAM and AAM systems in August 2015.

4.2. August 2015

The August field trials involved deploying bottom mounted frames holding monitoring equipment at two sites in the Sound of Sleat (#1 on Figure 2) and Kyle Rhea (#2 on Figure 2). The exact locations of the deployments are given in Table 4. The trials had the following aims:

AAM:

- a) Test deployment and operation of twin Gemini sonars on a fixed seabed mounted platform for a period of weeks;
- b) Investigation of the imaging capabilities of the sonars from a seabed mounted perspective (evaluate effects of surface turbulence/wave action on the sonar data);
- c) Collection of data to validate the marine mammal classification algorithms (sonar data in combination with visual observations of marine mammals);
- d) Collection of data to validate 3D marine mammal tracking (seal carcass towed through the sonar beams);

- e) Investigate biological growth on the sonar transducers over a longer period of deployment;
- f) Deploy an EK60 echo sounder to evaluate potential cross talk between the sonars (this is because of plans to deploy an EK60 as part of the extended monitoring at the MeyGen site)

PAM:

- a) Test deployment and operation of two domed hydrophone clusters on fixed seabed mounted platforms for a period of weeks;
- b) Investigation of detection probability and localisation accuracy of the hydrophone clusters;
- c) Investigation of the ability to detect and track VEMCO acoustic pinger tags (these tags could be fitted to seals so they could be detected and tracked with the PAM);
- d) Deploy an EK60 to evaluate potential interference with PAM monitoring and understand the potential for the EK60 signal to influence the behaviour of marine mammals;
- e) Evaluation of dome shape and hydrophone spacing.

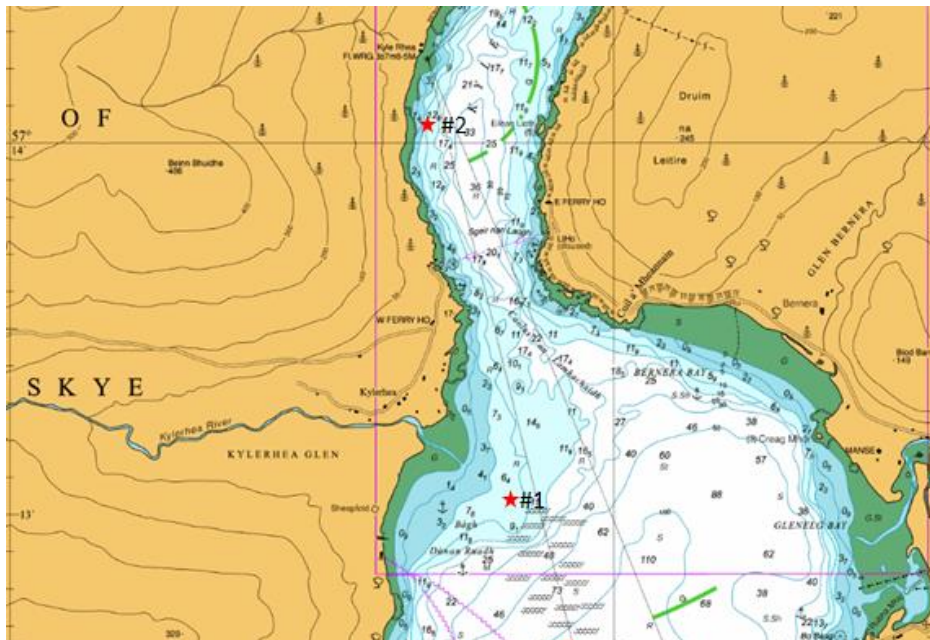

Figure 2: Chart of the Sound of Sleat (#1) and Kyle Rhea (#2) with the mooring and deployment positions indicated.

Table 4

Deployment locations of the three High Current Underwater Platform (HiCUPs).

HiCUP Unit	Longitude	Latitude
Active sonar HiCUP	5°39.606'W	57°13.019'N
Passive sonar cylindrical-top HiCUP (hydrophone channels. 0, 1, 2, 3)	5°39.631'W	57°13.010'N
Passive sonar spherical-top HiCUP (hydrophone channels. 4, 5, 6, 7)	5°39.603'W	57°13.039'N

4.2.1. HiCUP Design

A High Current Underwater Platform (HiCUP) for housing the monitoring equipment was designed and built for these trials. The requirement was for a structure which could be placed on, and retrieved from, the sea bed by a relatively small non-specialist, locally available vessel, would be stable on uneven terrain and would not move in tidal currents of up to six knots. Additional considerations were that it should be possible to break the structure down so that it could be transported on a standard Euro-pallet. The dimensions (0.5 m high and 1.8 m from centre to end of each leg), shape and design were based on calculations of turning moments and stability for a structure in a high tidal current. These dictated a structure which was heavy, had as low a profile as possible, a broad base and three points of contact (Figure 3). Each HiCUP was fabricated in steel with 400 kg of lead ballast, and each had an overall weight of 1000 kg. Three of these platforms were constructed, one for the deployment of the dual Gemini sonars and two for the deployment of two hydrophone clusters. The PAM (Section 5) and AAM (Section 6) sections below provide more detail on the HiCUP equipment deployments in August 2015. Figures 4 and 5 show the platforms being deployed and the vessel used for deployment.

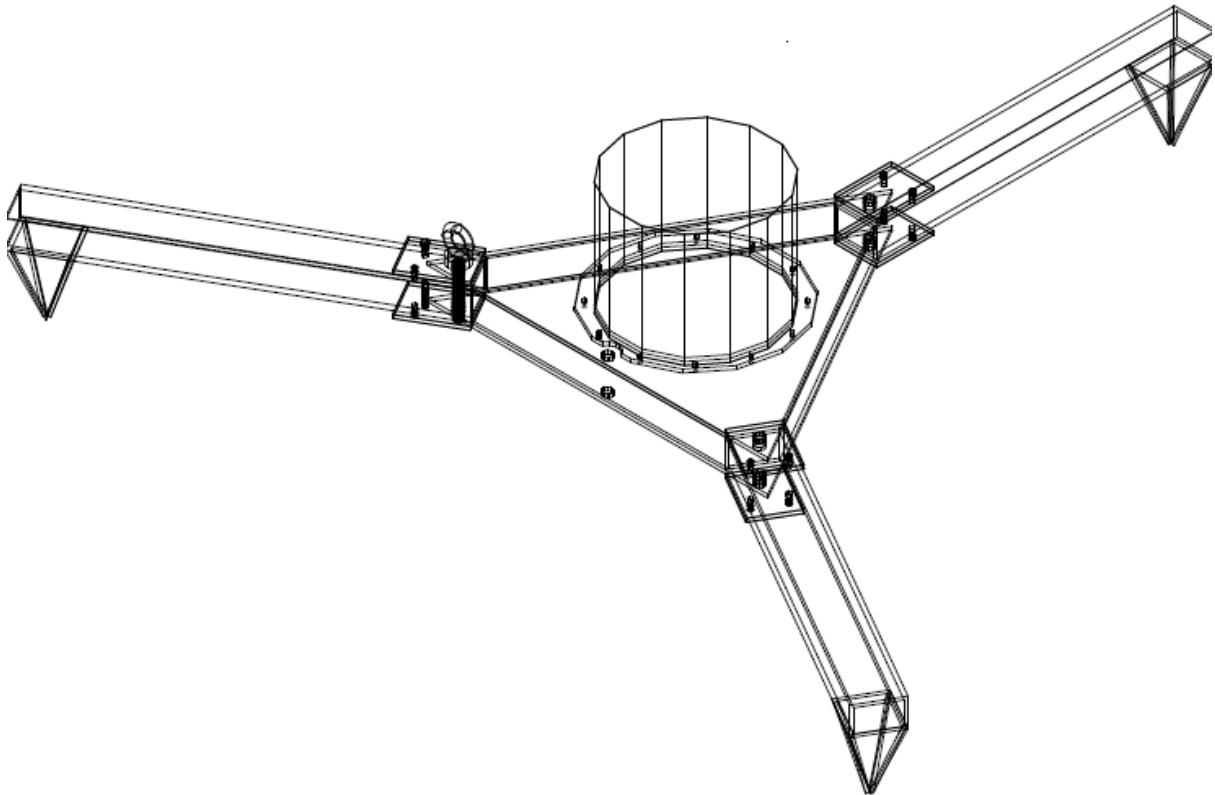

Figure 3: Design of Hi Current Underwater Platform (HiCUP).



Figure 4: Hi Current Underwater Platform (HiCUP) with dual sonar configuration being deployed in Kyle Rhea.



Figure 5: Research vessel in the north-western part of the Sound of Sleat, cabled to underwater passive and active acoustic HiCUP clusters, in August 2015.

5. Passive Acoustic Monitoring System Testing and Development

Previous work showed that arrays of multiple hydrophones are capable of localising and tracking echo-locating harbour porpoises. In particular, this work showed that in spite of the narrow beam of sound produced by this species, clicks were detected on hydrophones sufficiently far apart for accurate 3D localisation (Macaulay *et al.*, 2015). The study used drifting vertical arrays consisting of a small tetrahedral structure close to the surface with an additional four or eight hydrophones hanging in a vertical line. For a given number of hydrophones optimal localisation will, in principle, be achieved with the hydrophones spread out individually about the volume of interest. In real working conditions, each individual deployed hydrophone carries with it cabling and mounting infrastructure costs as well as the requirement of knowing exactly how each hydrophone is positioned. Furthermore, it may be difficult to match clicks on widely spaced hydrophones, particularly when time of arrival differences between different hydrophones approach typical inter-click intervals for the species under study. The approach of mounting hydrophones in clusters of four in a tetrahedral geometry was therefore adopted. Each Tetrahedral Hydrophone Cluster (THC) can estimate unambiguous bearings to detected sounds, but provides no range information. When data from two or more THC's are combined, three dimensional tracking is possible. Each THC has dimensions in the range 30-50 cm,

meaning that they can be constructed and mounted as single units, thereby reducing cabling and siting complexity and cost.

5.1. Methods

5.1.1. Hydrophone Cluster Design

Hydrophones within each THC need to be rigidly supported, but using a minimum of material so as not to cause reflections and distortions in the sound paths between each hydrophone, reducing the accuracy of timing measurements. At the same time, each cluster needs to be physically strong in order to survive the high energy environment around a tidal turbine and collisions with matter (seaweed, debris, etc.) moving in the tidal flow. To satisfy the conflicting needs of a light structure and a strong structure, THCs were mounted on a light frame, housed within a physically strong, but acoustically transparent cowling. High density polyethylene was identified as a material having an acoustic impedance close to that of seawater. This is a material which is physically robust and easy to weld. It is widely used for construction in the fish farm industry and is also used for the hulls of small working vessels.

Table 5
Hydrophone cluster specifications.

	Cylindrical Cluster	Spherical Cluster
Hydrophone Spacing	30 cm	15 cm
Hydrophone element	6 mm cylinders	12.5 mm spheres
Cowling Shape	Flat topped cylinder	Domed
Distance hydrophone to wall (time for sound to travel that distance)	7.7 cm (102µs)	16.3 cm (218µs)

Two THCs were constructed, one with a 30 cm spacing between hydrophones, the other with a 15 cm spacing. The 30 cm spaced hydrophones were made from 6 mm cylindrical ceramics, the 15 cm spaced ones from 12.5 mm spheres. These were housed under two differently shaped cowlings, the first having a flat top and the other a more domed shape (Table 5). Flanges were welded to the two cowlings so that they could be securely bolted to a plywood base supporting the hydrophone mounts (Figure 6).



Figure 6: Polyethylene cowlings, on a plywood base, used to protect the two hydrophone clusters.

In order to demonstrate that this arrangement of multiple hydrophone clusters around a turbine would provide the required detection and localisation range and accuracy for monitoring the fine scale behaviour of echo-locating cetaceans around a tidal turbine, a number of developments and experimental trials were required:

- Testing of the THCs on fixed seabed mounted platforms in an area of tidal current for a period of weeks;
- Investigation of detection probability and localisation accuracy of the hydrophone clusters;
- Evaluation of cluster cowling shape and hydrophone spacing;
- Investigation of the potential for interference from the Tritech Gemini sonars;
- Development of data acquisition system to allow stable recording of 12 channels of data simultaneously.

5.1.2. Tag Detection and Tracking

In addition to the primary task of detecting and tracking small cetacean species, the possibility of using the PAM system to track tagged seals was investigated. Neither harbour nor grey seals regularly vocalise, therefore, it was suggested that if a number of local seals were to be fitted with acoustic pinger tags, any interaction with the turbine could be detected by the PAM system. Acoustic pinger tags are mainly used in fish studies and the commercial availability of such fish tags was reviewed. For this study the tags should:

1. Transmit frequently (interval ≤ 1 s) to provide sufficient temporal resolution;
2. Last at least three months;
3. Be detectable by bespoke PAMGuard algorithms;
4. Be individually identifiable;
5. Be capable of being tracked by the PAMGuard system;
6. Interfere minimally with seal behaviour.

The preferred pinger tag was the VEMCO V16P-6H continuous transmitter (<http://VEMCO.com/wp-content/uploads/2014/05/v16-cont.pdf>) which transmits at a frequency of 83 kHz every 1-2 s (depending on depth) and has a longevity of approximately 100 days (see Figure 7).



Figure 7: VEMCO V16P-6H continuous transmitter tag.

Unfortunately, the VEMCO tag does not encode its identity number and so does not satisfy criterion four, above (be individually identifiable). However, if these animals are also tagged with identifiable GPS transmitting tags (e.g. Fastloc UHF tags), these will provide locational information for each seal and, therefore, any detections of pinger tags on the PAM system can be linked to individual seals based on the GPS tag data.

It is possible that a seal would be able to detect faint clicks from this tag at the start of each transmission, although this possibility requires formal investigation. Furthermore, 83 kHz is within the hearing range of predators of seals [killer whale (*Orcinus orca*) auditory threshold at 80 kHz has been reported as 65-78 dB (Szymanski *et al.*, 1998)] and there is a clear risk that they could passively detect these tags if deployed on seals. It is unlikely that prey species would hear the tags.

5.1.3. Sound of Sleet Deployments

The Sound of Sleet site field deployment consisted of three steel tripod HiCUP frames. One held two Gemini 720 kHz multi-beam sonars (see Section 6) and the other two each held a THC unit. The frames were connected to a concrete block attached to a buoy at the surface (Figure 8).

Unfortunately, an error in deployment location led to the equipment being deployed approximately 100 m from the planned location position. This meant that the equipment was deployed in shallower water than was anticipated (~8 m, instead of 15 m) and out of the main current. In addition, the contractor deployed the two PAM HiCUPs 50 m apart rather than the 20 m specified. This had implications for the probability of detecting porpoises simultaneously on both clusters and therefore tracking probability.

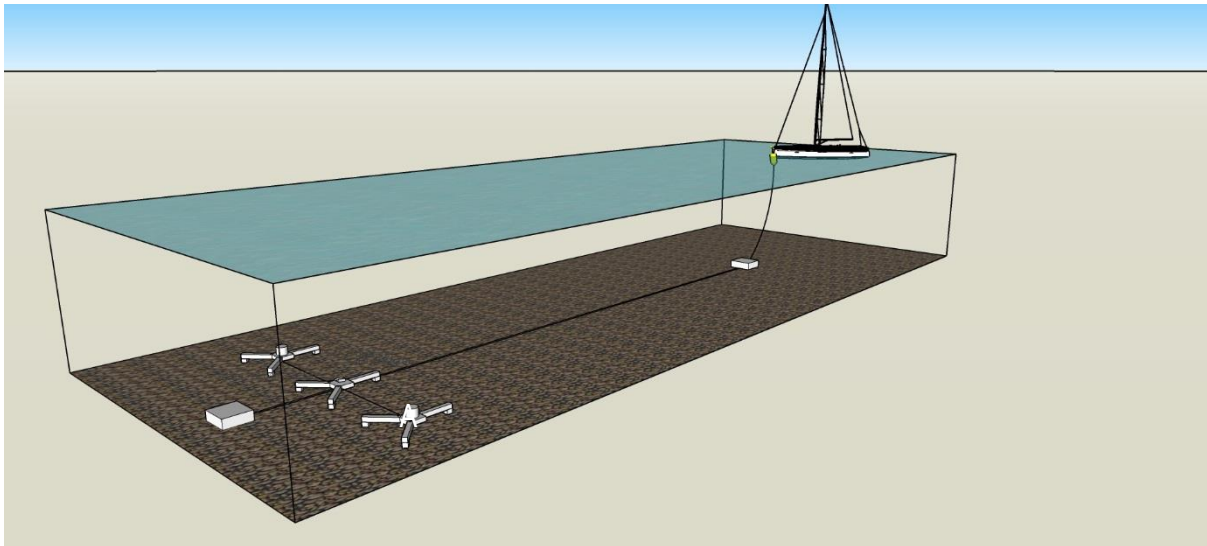

Figure 8: Configuration of mooring and instrument deployment at the Sound of Sleat.

The two THCs (described above) were deployed on the outer two HiCUPs with the pair of Gemini sonars on the central one (Figure 8), with cables from all three HiCUPs run to a boat moored on a second concrete mooring block some 80 m away in slacker water. Signals from all eight hydrophones were conditioned and amplified on the vessel before being digitised and stored as WAV files using a boat-based computer and data acquisition system sampling at 500 kHz. Occasionally, the vessel would have to leave the mooring, either due to poor weather or the need to resupply. When disconnected, waterproof blanking plugs were fitted to cable ends from the HiCUPs and the cable ends tied off to a buoy and left floating next to the mooring. Passive and active data were recorded continuously 24 hours a day to hard disk drives whenever the vessel was at the mooring.

5.1.4. Alignment and Calibration Trials

Calibration trials were conducted in order to determine both the location and orientation of each hydrophone element on each passive acoustic THC, and to evaluate the localisation accuracy achievable by these devices with representative signals in field conditions. These trials involved broadcasting simulated harbour

porpoise clicks and a frequency modulated click signal from a hydrophone at a known depth.

The calibration system was deployed from a drifting dinghy whose location was determined using GPS. A VHF radio link was used to synchronise the transmission time of each burst of signals on the broad band multi-track recordings made on the research vessel. For some trials, VEMCO “pinger tags” were also deployed to provide information on the tracking accuracy that could be achieved for active acoustic tags using the PAM system, and a sonar target was deployed to determine the location and orientation of the Gemini sonars. Calibration trials were carried out over a total of ~20.5 hours.

Sweeps from the calibration trials were used to localise the THCs by optimising their x, y, z locations, heading, pan and tilt to best fit the data. The simulated porpoise clicks were used to investigate localisation and timing accuracy.

5.1.5. Acoustic Data Analysis

PAM data were analysed using PAMGuard (www.PAMGuard.org; Gillespie *et al.*, 2008). An automated click detector with a porpoise click classifier, and whistle and moan detector to detect dolphin whistles, was applied to all collected data. For a narrow band, well defined signal, such as those from the VEMCO tags, an optimal detector would filter incoming data with a narrow band pass filter covering only the frequencies emitted by the tag(s) prior to detection. In principle it would be possible to run separate detectors for VEMCO tags and for cetacean clicks (which require a broader band detection system). While relatively straight-forward in the laboratory, for a future real time system, running two sets of detectors on multiple channels at high frequency would likely require more than one PC to process data at the required rate. Implementing data sharing between two PCs in this way is not possible with current software (Section 5.4), although it could probably be implemented if required. In order to avoid additional time consuming software developments, focus was placed on using a single detector for both cetacean clicks and VEMCO tags and to then separate the various click types using the PAMGuard click classification systems.

The PAMGuard click detector was, therefore, configured to detect transient sounds with energy between 70 and 150 kHz rising 15dB or more above background noise. Detected clicks were automatically classified as dolphin, porpoise or VEMCO tag based on their spectral properties. VEMCO tag sound clicks were identified by their concentration of energy at the known frequencies for these devices, whilst cetacean

and artificial calibration clicks were identified by their energy in the 100-150 kHz band. Sequences of porpoise and dolphin clicks received on either or both PAM clusters were identified by an experienced analyst and grouped into “encounters”. An encounter was defined as an instance when classified clicks grouped in clear click trains were recorded within ten minutes of one another (Figure 9).

If hydrophone locations are accurately known, then sound source localisation accuracy is largely governed by how accurately it is possible to measure time of arrival differences of signals at different hydrophones. In order to improve timing accuracy for the VEMCO tag signals, new timing algorithms were developed specifically for the long VEMCO signals. This work is described in detail in Appendix A.

Generated sounds originating from the same location should generate the same time delay measurements on each hydrophone pair. Timing accuracy was, therefore, measured by comparing time of arrival differences for adjacent generated porpoise clicks and fish tag pings, which being close together in time, would have originated from a very similar location. If each timing measurement error can be assumed to be independent, then the average error on each timing measurement is the difference in time measurements for adjacent clicks divided by the square root of two.

Absolute localisation accuracy was measured by comparing reconstructed locations of the artificial porpoise clicks broadcast during calibration trials with the source location.

Further investigations of localisation accuracy were then conducted with simulations, using the measured timing accuracies from the field trials as input to the simulation. This allowed a comparison of the hydrophone geometry used in these trials with the hydrophone geometry now planned for deployments on a tidal turbine later in 2016 to be made.

5.2. Results

The PAM system proved to be very reliable with data being collected nearly continuously when the vessel was present from 6 August until recovery on 25 August, 2015. As anticipated, the research vessel occasionally left the mooring and disconnected the HiCUP cables, resulting in gaps in data collection. A total of ~332 hours (~14.83 days) of acoustic data were collected by the HiCUP units (Table 6). Overall, data were successfully recorded for ~79% of the time between the initial

connection and final disconnection (~425.5 h available). In total 13.5 TB of data were collected.

Visual observations during the trials included harbour porpoises, bottlenose dolphins, grey seals, harbour seals, and Northern gannets (*Morus bassanus*).

A pod of ~20 bottlenose dolphins was sighted in the upper Sound of Sleat on 19 and 20 August. Table 6 shows the total number of passive acoustic encounters for both porpoises and dolphins. There were four instances where porpoise and dolphin encounters overlapped. Figure 9 shows a PAMGuard screenshot of a porpoise encounter. Figure 10 shows a screenshot of dolphin whistle detections.

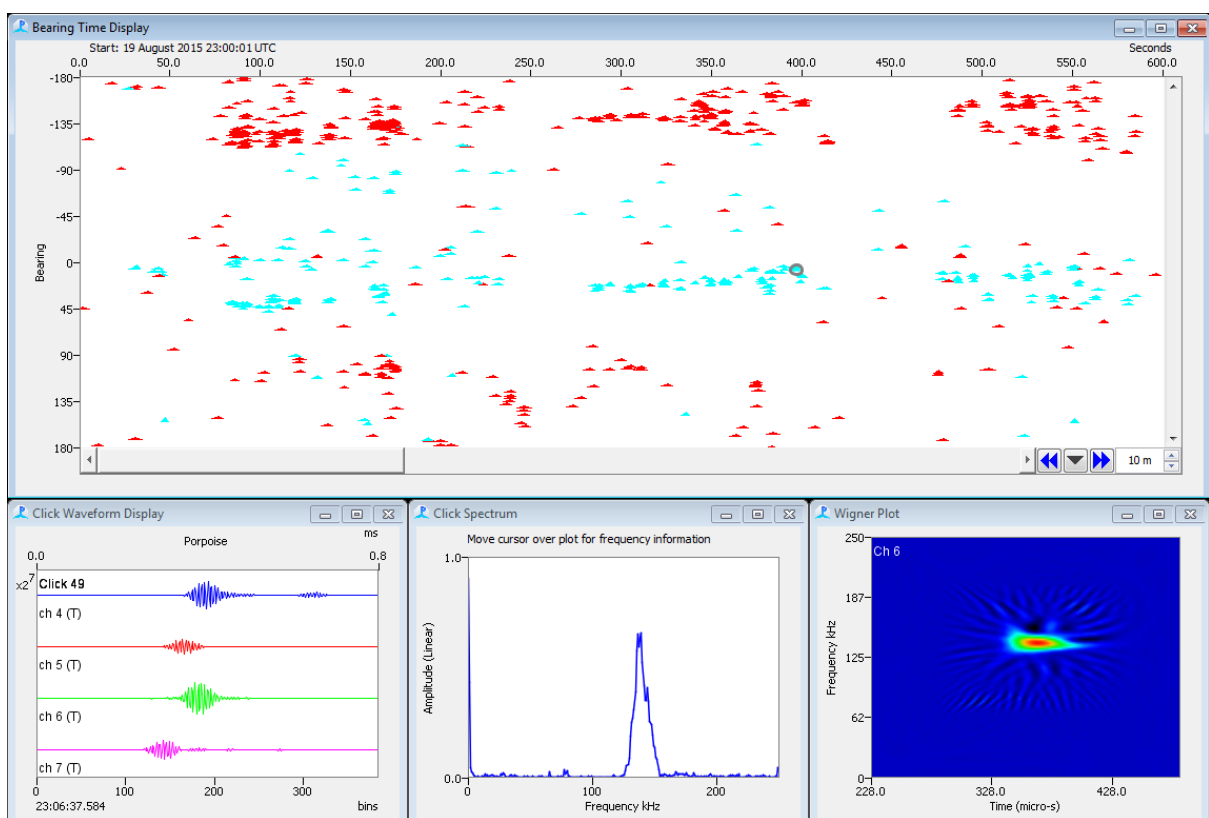

Figure 9: Screenshot from PAMGuard showing harbour porpoise click detections on both HiCUP clusters. Clicks are coloured by HiCUP cluster: red denotes the cylindrical cluster (ch. 0, 1, 2, 3) and cyan denotes the spherical cluster (ch. 4, 5, 6, 7). A bearing-time display (10 minutes shown), waveform display, click spectrum, and Wigner plot of a single porpoise click are shown.

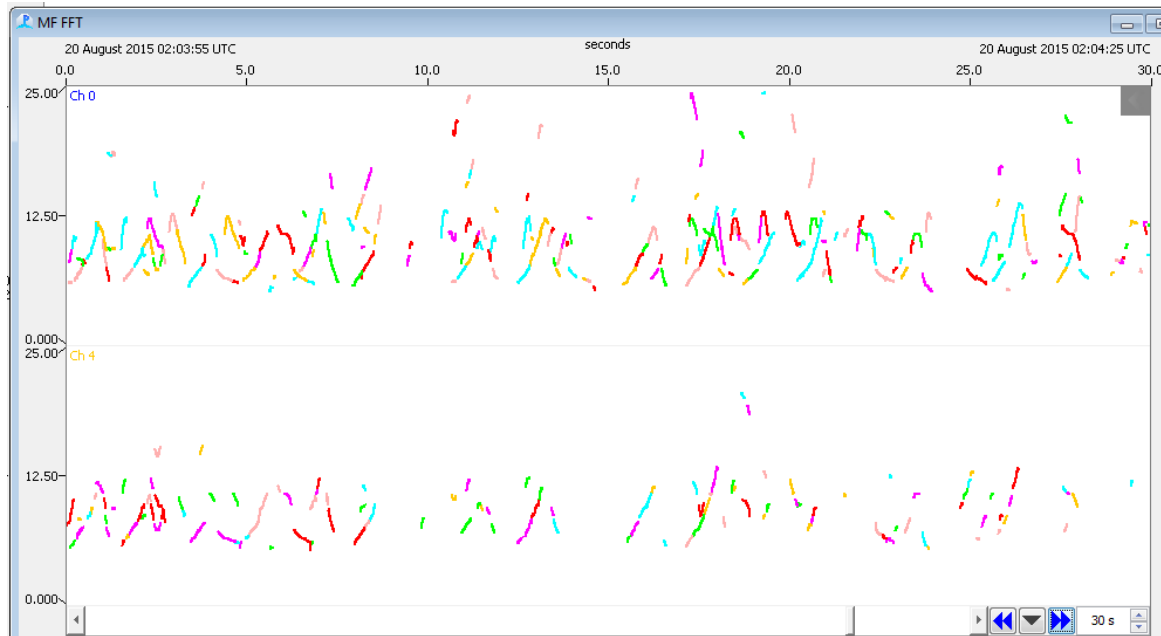

Figure 10: Screenshot from PAMGuard showing bottlenose dolphin whistle contours (30 s of data shown, 0-25 kHz). The top panel shows one channel (ch. 0) from the cylindrical PAM HiCUP cluster, and the bottom panel shows one channel (ch. 4) from the spherical PAM HiCUP cluster.

Table 6

Summary of porpoise and dolphin acoustic encounters.

Marine mammal species encountered	# of encounters	Duration of encounter (mean, min-to-max)	Total duration of encounters (hh:mm:ss)	% of entire recorded time containing encounters
Harbour porpoise	64	00:38:37 (00:00:33 to 04:15:57)	41:11:31	12.4%
Bottlenose dolphin	22	00:35:14 (00:00:43 to 02:35:43)	13:30:21	4.1%
Porpoise and dolphin	4	n/a	4:47:10	1.4%

5.2.1. HiCUP Location

The location of the HiCUPs was calculated from time of arrival differences from frequency modulated clicks outputted at different known locations around the array. Table 7 shows the locations and orientation results and associated errors calculated using two different optimisation algorithms (grid search and simplex). Figure 11 shows a latitude and longitude plot of the calculated locations and errors for both algorithms. The difference in positions calculated by the two methods for the spherical and cylindrical clusters is 3.4 and 1.2 m respectively.

Table 7

Table showing the calculated positions and orientations of the hydrophone clusters along with associated errors in each measurements. Note that the grid search assumed pitch and roll was zero.

PAM HICUP type	Latitude	Longitude	Depth (m)	Heading (degrees)	Pitch (degrees)	Roll (degrees)
Grid Search						
Spherical	$57.21730772 \pm 3.72 \times 10^{-5}$	$-5.660049997 \pm 3.83 \times 10^{-5}$	-7.8 ± 0.94	150 ± 3.06	-	-
Cylindrical	$57.2168693 \pm 2.37 \times 10^{-5}$	$5.660649391 \pm 7.66 \times 10^{-5}$	9.9 ± 0.79	320.5 ± 3.7	-	-
Simplex						
Spherical	57.2172972	-5.6600553	8.75	150.9	-2.9	0.6
Cylindrical	57.2168987	-5.6606335	7.83	317.7	-2.8	4.4

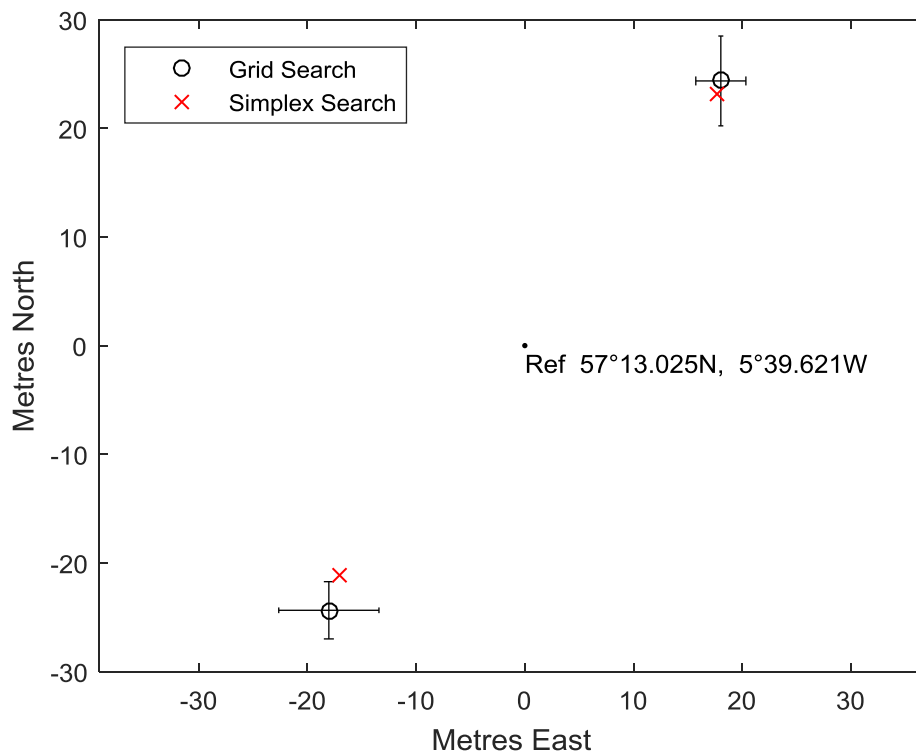

Figure 11: The calculated position of the HiCUPs using two different minimisation methods, grid search and simplex.

5.2.2. Timing Accuracy

Figure 12 shows typical received pulse waveforms from a 120 kHz 'porpoise' signal generated during a calibration trial. For comparison, the figure also shows the original pulse waveform, time aligned to the start of the received pulse on each channel. Significant and differing signal distortion and multiple echoes of the signal following each received pulse are clearly visible on all channels.

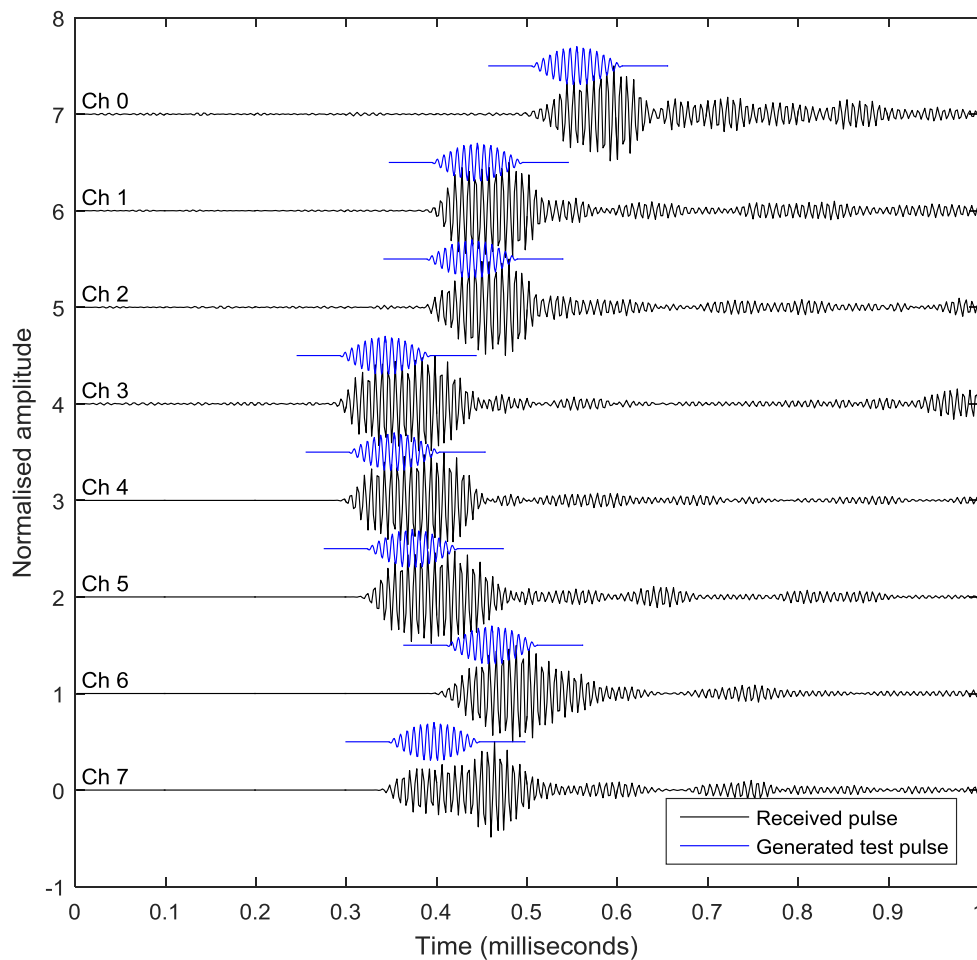

Figure 12: Example pulses received on all eight hydrophones (four in each cluster) from a pinger calibration trial using porpoise like clicks. Shown with each received pulse is the pulse used to generate the calibration sound aligned to have the same start time as each received pulse. Distortion of the pulses and multiple echoes following each pulse are clearly visible.

Alignment problems with the HiCUPs and small uncertainties in the location of the drifting sound source, make it difficult to accurately assess timing accuracy based on the difference between measured received times at the hydrophones and expected received times based on the system geometry. Timing accuracy was, therefore, investigated by comparing the time delays of adjacent clicks during the experiments

with an artificial sound source. With zero timing error, the difference in time delays between adjacent clicks should be negligibly small, so any difference is presumably caused by errors in the timing measurements. Timing accuracy and algorithms for extracting time of arrival differences are discussed in Appendix A.

Table 8

Summary of timing errors for porpoise like clicks and VEMCO fish tags using different cross correlation methods.

Signal Type	Waveform Correlation		Envelope Correlation		Envelope Edge Correlation	
	Cylinder	Spherical	Cylinder	Spherical	Cylinder	Spherical
Porpoise	6.3 μ s	5.1 μ s	6.2 μ s	4.7 μ s		
VEMCO tags	31.1 μ s	25.5 μ s	21.1 μ s	14.6 μ s	11.5 μ s	7.4 μ s

Measurements of timing accuracy for both hydrophone clusters and different correlation methods are shown in Table 8. It can be seen that for the porpoise clicks, there is little difference between waveform and envelope correlation. In comparison, for the long duration VEMCO tag signals, there is a three-fold improvement in timing accuracy when envelope edge correlation is used in preference to waveform correlation.

It can also be seen that timing accuracy is consistently better on the spherical hydrophone cluster than on the cylindrical one. In addition to differences in the hydrophone ceramic, there were two important differences between the two clusters. One was the shape of the cowling, where the cylindrical cluster cowling had a flat top and the other a domed top. The other difference was in the spacing between hydrophones, which was 30 cm for the cylindrical cluster and 15 cm for the spherical cluster. The wider hydrophone spacing meant that hydrophones were closer to the cowling material, so the time delay between the incident signal and any echo from the structure was shorter than for the more tightly spaced hydrophones (7.7 cm and 16.3 cm respectively, giving two way travel times of 102 and 218 μ s). The longer spacing between clicks and echoes in the cylindrical cluster would mean they were less likely to overlap and distort the waveforms. It is, therefore, possible that the signals on the more widely spaced hydrophones were more distorted by echoes than on the closely spaced cluster.

5.2.3. Localisation Accuracy

Once the location and orientation of each HiCUP was determined (Section 5.2.1), the broadcast porpoise pings were localised in order to determine the absolute tracking accuracy of the array. Detected broadcast pings were passed to the PAMGuard Large Aperture Localiser Module (Figure 13). This module outputs the latitude, longitude and depth of each broadcast sound detected on both HiCUPs. Localisations were then compared to the true position of the broadcast pinger and the error estimated for different ranges.

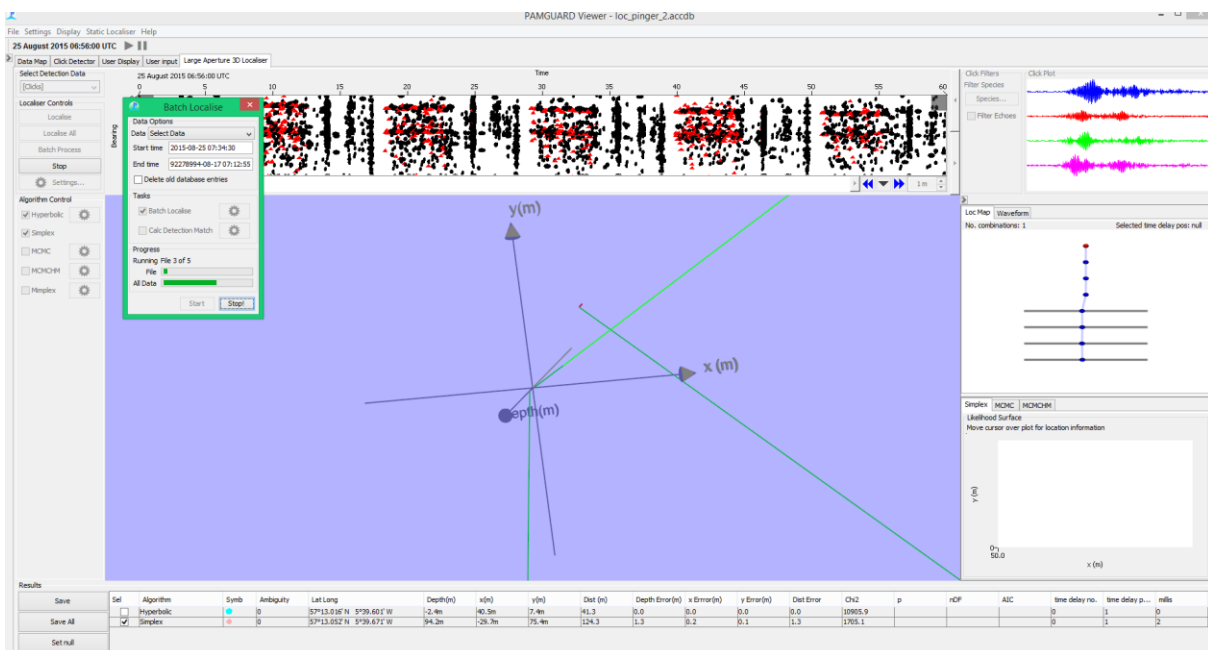

Figure 13: The PAMGuard Large Aperture Localiser module used to localise the position of simulated sounds and harbour porpoise and dolphin clicks.

5.2.3.1. Localising the Position of Broadcast Pings

Figures 14, 15 and 16 show the position, range and depth of the broadcast pings compared with reconstructed positions from data collected on the THC array. The true location of the broadcast pinger was compared to the localisation results and resulting errors calculated. Figures 17, 18 and 19 show range, depth and angular errors divided into 25 m range bins.

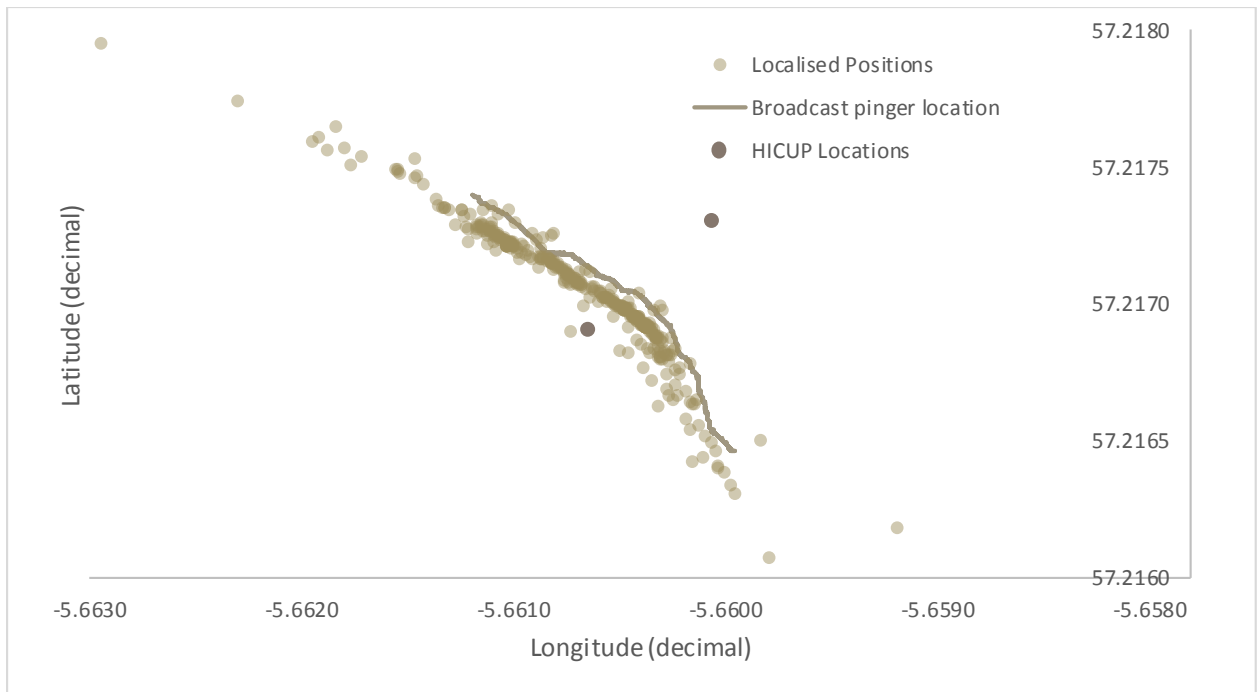

Figure 14: A sample of the latitude and longitude of the broadcast pinger and the localised position calculated from acoustic data collected on the HiCUP array.

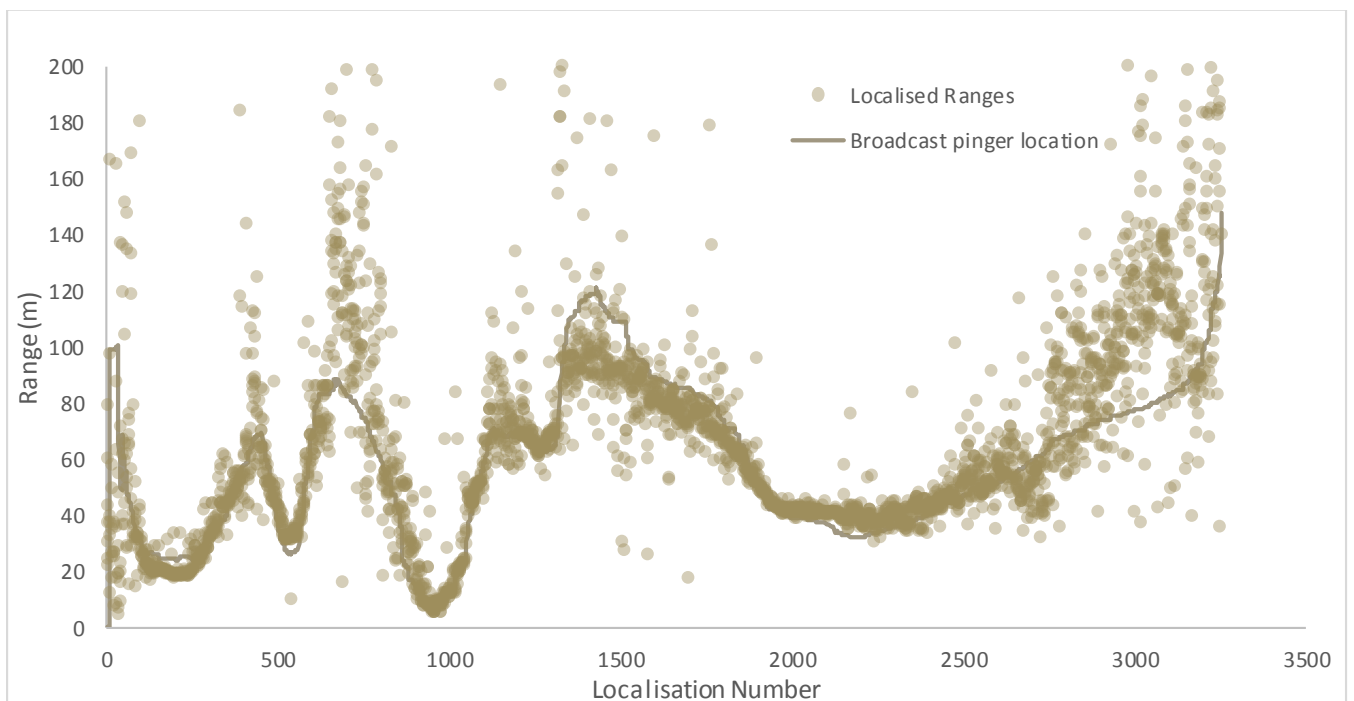

Figure 15: The range of the broadcast pinger and localised ranges calculated from the acoustic data collected on the HiCUP array. The localised ranges broadly follow the true range of the broadcast pinger.

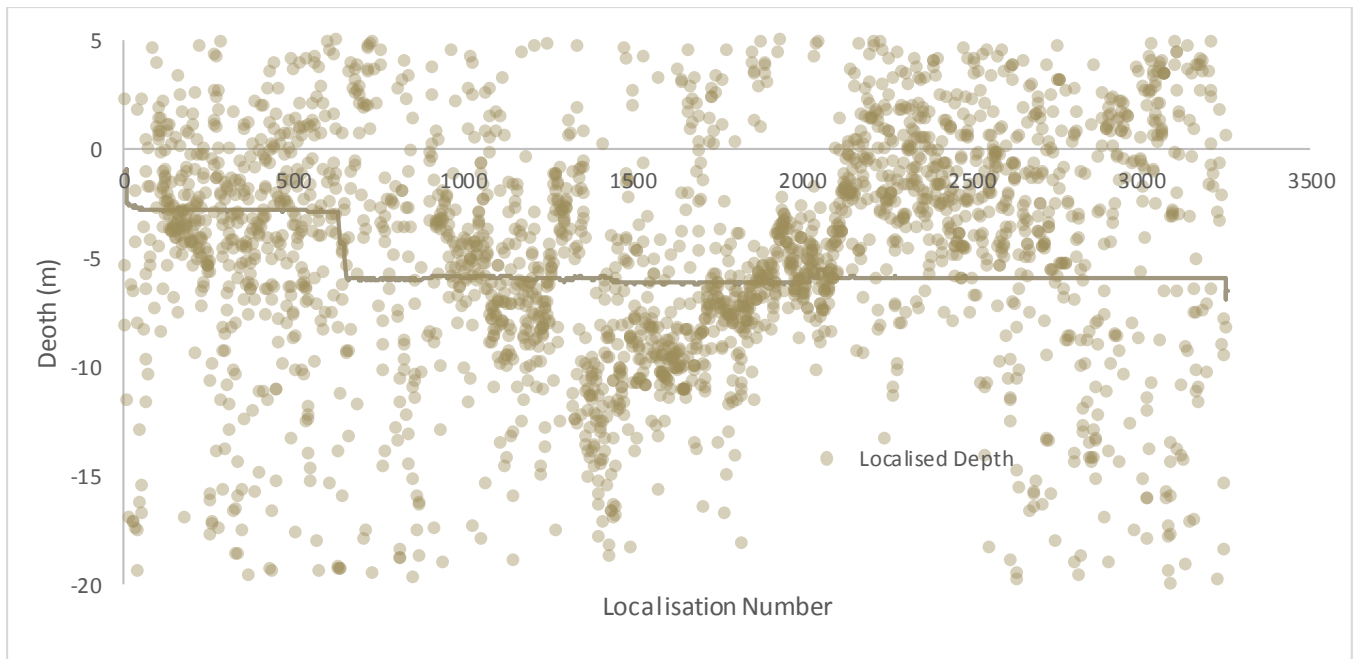

Figure 16: The depth of the broadcast pinger and localised depths calculated from the acoustic data collected on the HiCUP array.

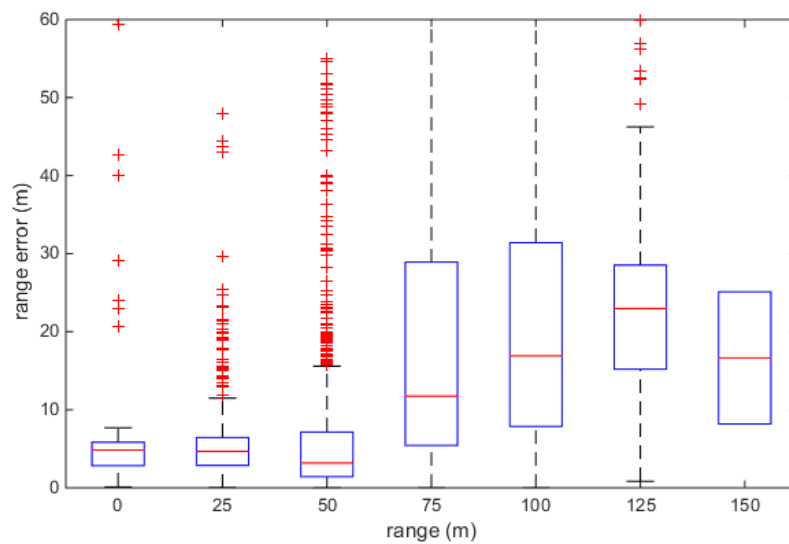

Figure 17: Box plots showing the median error in localised range of the broadcast pinger versus the true range of the broadcast pinger.

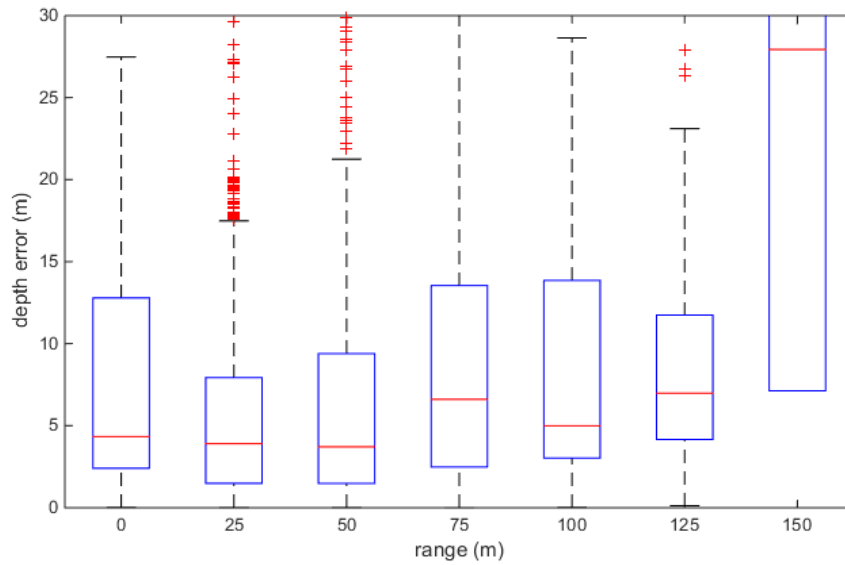

Figure 18: Box pots showing the error in localised depth of the broadcast pinger versus the range of the broadcast pinger.

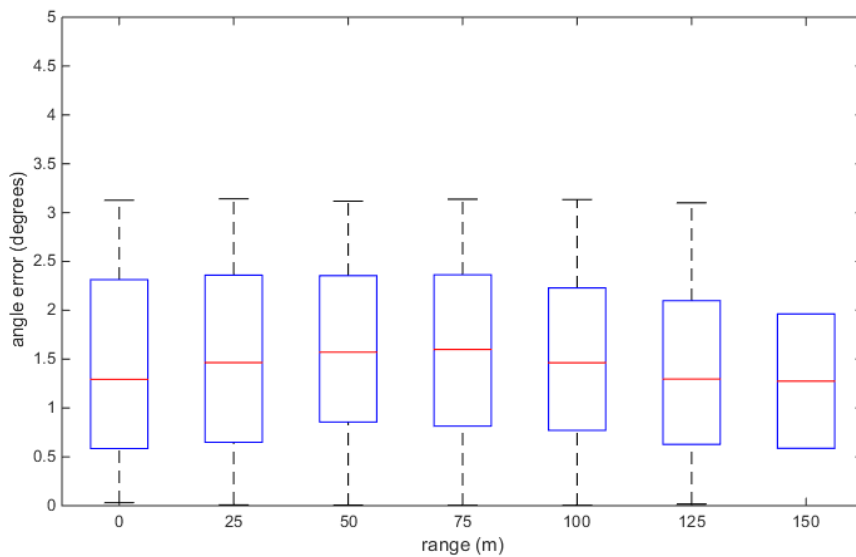

Figure 19: Boxplots showing the error in the angle to the broadcast system versus the true range of the broadcast system.

The systematic offsets in Figure 14, in which estimated localisations of the sound source appear to the south west of the true locations are indicative of an offset (i.e. a systematic error) in the location of the HiCUP clusters. Generally, range error is small (3-6 m) out to about 50 m from the array. Depth error appears to be higher and more variable at least several meters at all ranges. It has not been possible to fully ascertain the cause of this, but it is most likely caused by a tilting of the HiCUP clusters.

5.2.4. Fish Tag Detection Range

In order to assess detection range, two types of fish pinger tags were suspended below a slowly moving inflatable in the vicinity of the THC's: a 83 kHz tag (the tag that is proposed to fit on seals) and a 69 kHz tag. The exact times and numbers of transmissions of pings is not known, so the numbers of received pings per unit time was compared with the amount of time the drifting dingy spent in each range bin. Most data were collected with the tags within 100 m of the HiCUPs and few data were collected at ranges greater than 200 m. However, from Figure 20 it can be seen that detection rate of both tags is reasonably flat out to 100 m and some detection occurs out to at least 250 m.

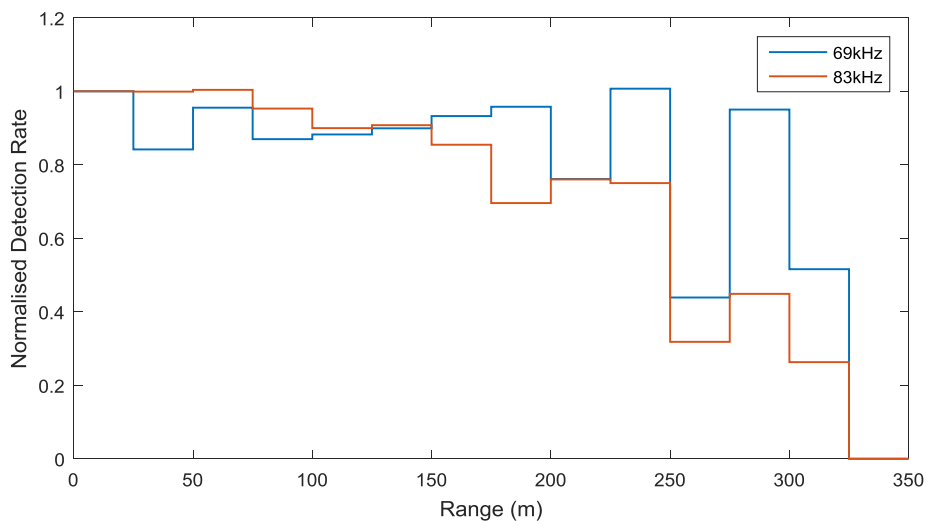

Figure 20: Detection rates for 69 and 83 kHz VEMCO fish tags as a function of transmission distance.

It should be remembered that the detection parameters used for this trial were not optimised for the VEMCO tag signals, but were generic settings designed to detect echolocation clicks over a wide bandwidth. If the detection parameters were optimised for this type of sound, it is likely that much greater detection ranges could be achieved although localisation accuracy could be compromised.

5.3. Localisation Error Simulation

Measurements of localisation accuracy (presented in Section 5.2) may underestimate the likely localisation accuracy of a system installed on an operational turbine for two main reasons. Firstly, there were problems with the alignment of the THC's and this will have contributed to the errors described in Section 5.2.3. Secondly, the current plan is now to install three hydrophone clusters on one of the turbines installed at the MeyGen site, one cluster on each of the three legs. The

improved alignment that will be achieved by mounting on the turbine structure, combined with an increased number of hydrophones in a different geometry should improve tracking accuracy.

Localisation accuracy was, therefore, investigated using simulations, both for the HiCUP configuration of two THC's 50 m apart and also for a system consisting of three clusters in a triangular configuration with a nominal 10 m spacing.

The hydrophone clusters in the simulation were set at 10 m depth. The PAMGuard sound acquisition module was used to create a series of simulated clicks positioned on a 100 x 100 m grid with depths at 0 m, 5 m and 10 m. Errors in sound speed, hydrophone location and click cross correlation were all incorporated into the simulation using the values shown in Table 9. The timing error of 5 μ s is taken from the timing accuracy measurements presented in Table 8. A Markov chain Monte Carlo (MCMC) based localisation algorithm was then used to localise each simulated click in the PAMGuard Large Aperture Localisation Module. The MCMC algorithm creates a dynamic representation of error distributions and hence can predict where areas of high and low localisation error might occur around a hydrophone array. Surface plots of the errors estimated through simulation are shown in Figure 21. Localisation accuracy in line with the two clusters is extremely poor once outside the space between the clusters, since movement away from the THCs creates no changes in time differences. Localisation accuracy with two clusters is reasonably directly perpendicular to the two clusters, the error in range being: < 3 m; depth < 2 m and angle < 0.7 degrees at 25 m. With three clusters, localisation accuracy improves, the average error in range being < 3 m; depth < 0.7 m and angle < 0.5 degrees at 25 m.

Except at close range, there is broad agreement between the measured and simulated errors in range and depth for the HiCUP THC configuration (Figure 22). Measured angle errors are consistently worse than the simulated errors. This difference is attributed to problems accurately aligning the HiCUP THC clusters during the field trials. The broad scale agreement means that, should alignment issues be resolved, either array configuration could provide accurate tracking around an operational turbine.

Simulations were also conducted using a slightly higher timing error of 7.5 μ s, which is the timing error achieved when using the VEMCO tag signals. It was found that the increased timing error made very little difference to localisation accuracy at ranges of less than 70 m, indicating that it should also be possible to track tagged seals using the PAM system to 1-2 m accuracy in the vicinity of the turbine blades.

Table 9

Error values in the simulation of hydrophone array accuracy.

Error Type	Error value
Sound Speed Error	10 ms ⁻¹
Hydrophone position Error	1 mm
Cluster Position Error	3 cm
Cross correlation error	5 μs

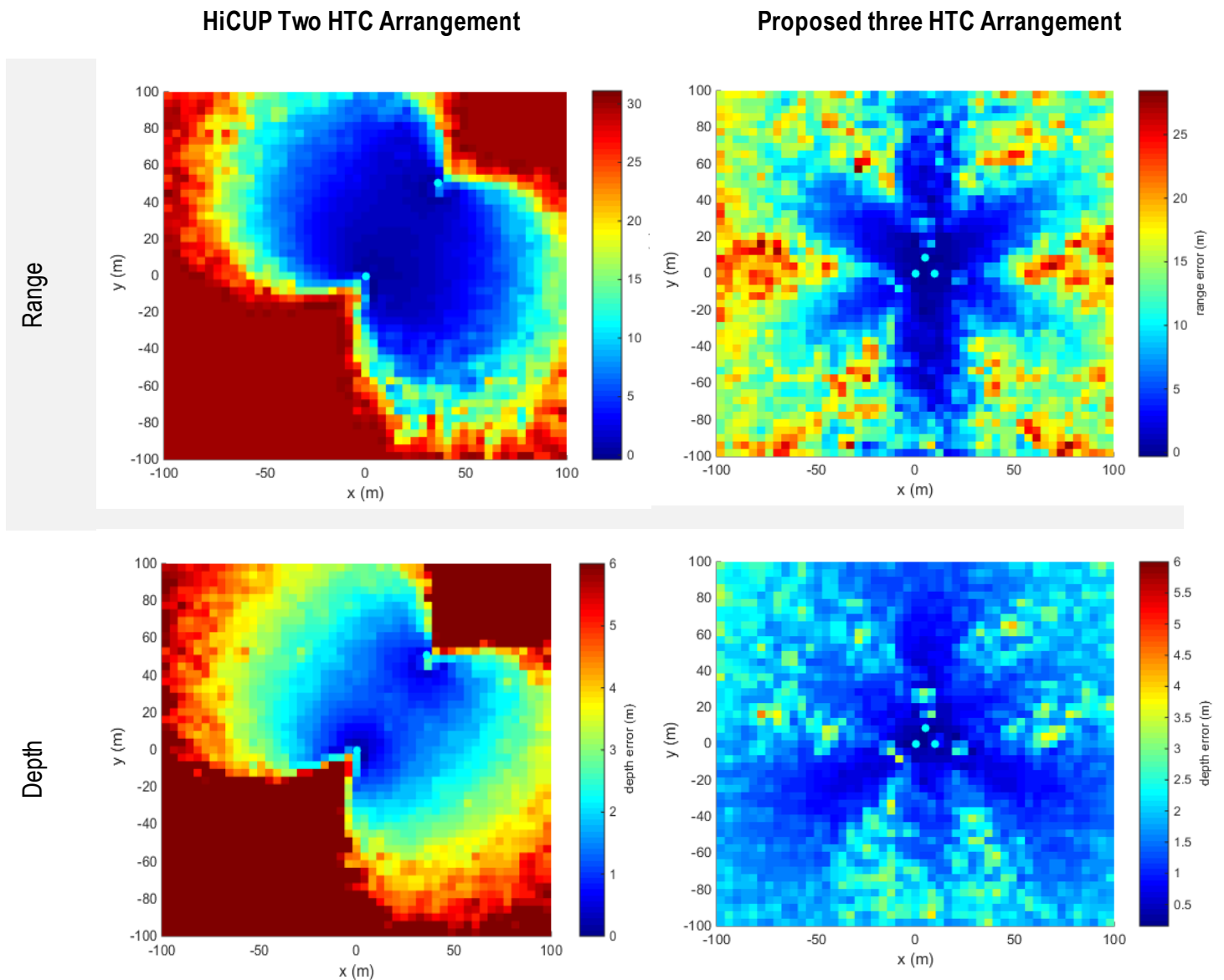

Figure 21: Simulated error surface for the HiCUP array and the proposed array to be deployed on a tidal turbine. The errors were calculated using a Markov Chain Monte Carlo based localisation algorithm to accurately estimate probability distribution in location. The estimated errors input into the model are shown in Table 9.

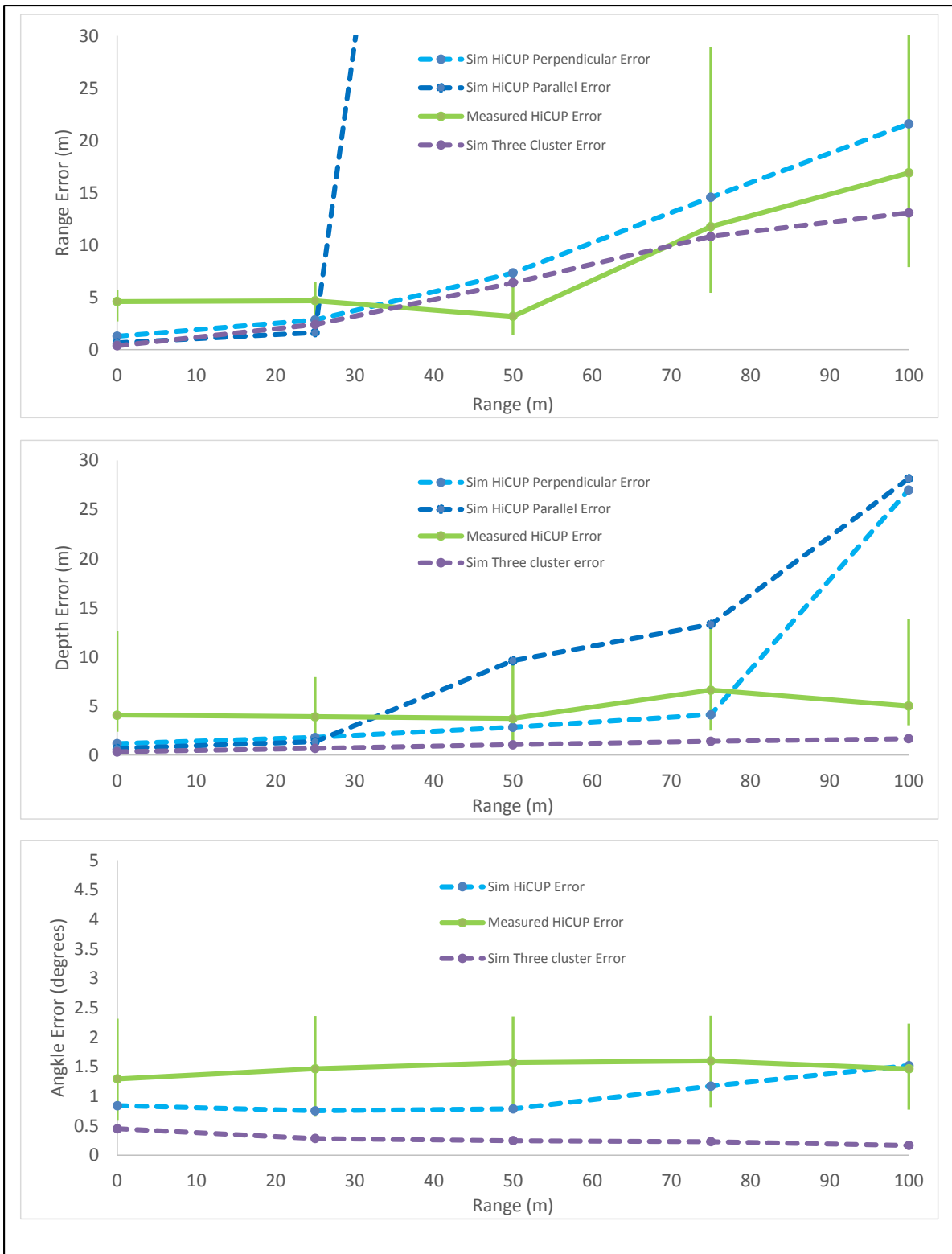

Figure 22: Measured and simulated errors for the HiCUP configuration and for a three cluster geometry. For the two cluster HiCUP geometry, errors are shown along a line parallel to the two clusters and a line perpendicular to them. For the three cluster geometry, errors for all angles are grouped together. These are overlaid with measured errors from the 2015 field trials.

5.4. Data Acquisition and Processing Development

To achieve the full functionality required for operation on a tidal turbine, two significant software developments have been undertaken. The first is in support of accurate timing (and, therefore, localisation) of fish tag detection, the second is to support higher data throughput from a twelve hydrophone PAM system.

5.4.1. Click Timing Measurements

To allow different time of arrival delay (TOAD) measurement algorithms to be used with different click types, the PAMGuard software was modified so that the choice of TOAD algorithm is selected separately for each category of classified clicks (see Appendix A). For each click type, it is now possible to define:

1. A filter to apply to the waveform data after detection and before TOAD measurement, to limit analysis to frequency bands of interest.
2. Whether to cross correlate the filtered waveform or the waveform envelope.
3. An option to use only the leading edge of the waveform envelope for cross correlation.

As with all PAMGuard development, these additions to the code are freely available to all users and developers under the GPL3 open source licence agreement (<http://www.gnu.org/licenses/gpl-3.0.en.html>). Examples of the configuration dialogs are shown in Figure 23.

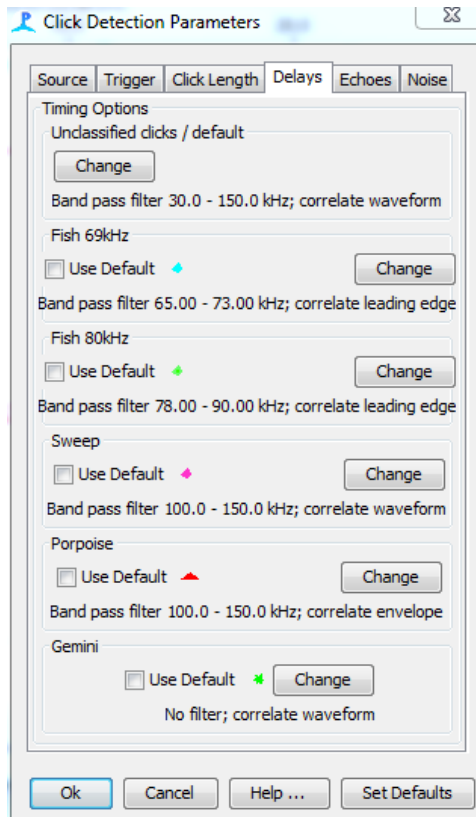

Figure 23: Configuration dialogs for click type specific timing measurement.

5.4.2. Data Acquisition System

During the 2015 field trials, data acquisition used two or three USB connected SAIL Daq Cards (St Andrews Instrumentation Ltd., <http://www.sa-instrumentation.com/>). Unfortunately, these are not suitable for deployment in a remote turbine site due to the limitations in USB cable lengths. For remote deployment, a new Data Acquisition system has been developed, based around a National Instruments cRio 9067 chassis equipped with NI 9222 analogue input modules, capable of sampling at 500kS/s on each channel. This is a significant development upon earlier work using a NI cDaq 9188 chassis which has been deployed on a similar installation. Since purchasing the 9067 chassis a smaller four slot version has become available which offers some space savings over the 9067.

The main difference is that the earlier 9188 chassis was a 'dumb' device which was only functional when being controlled directly by the host PC. The 9067 has its own internal processor which has been programmed to acquire, compress, and buffer data prior to transmission to the host computer. When acquiring high sample rate data on many channels, the 9188 based system can drop out due to buffer overflows when it fails to transmit data sufficiently quickly to the host PC. This then requires a restart of the system which can take several seconds. Using the 9188 chassis, this

was a serious problem when an Ethernet connection to the chassis was shared with other devices, but was less of a problem when a dedicated optical fibre was used for the NI-9188 to PAM PC connection alone. One of the advantages of the new system is that data compression and increased buffering are on the on-board computer. Compression reduces the network bandwidth required by a factor three, and stability will also be improved by increased buffering. Thus, the new system will provide a more stable acquisition platform, particularly when sharing an Ethernet with other devices.

The NI 9067 development was started in order to provide a fully autonomous data acquisition capability for a separate Scottish Government funded project (Macaulay *et al.*, 2015). Like PAMGuard, all developments for the NI chassis are being made freely available under open source licence agreements.

In addition to software developments, the development of small circular format preamplifier boards have been commissioned, suitable for mounting within a pressure housing. These are required between the hydrophones and the NI chassis and have been developed by Etec, Denmark (<http://www.etec.dk/>). Design rights remain with Etec and units can be purchased on commercial terms for other projects.

The NI 9067 Chassis and Etec preamplifiers are shown in Figure 24. Tests of this chassis and of preamplifiers designed for the “front end”, i.e. mounting close to the hydrophone elements within each THC, are on-going to ensure system reliability and stability.



Figure 24: Photograph of the NI Chassis and Etec preamplifier boards purchased for this project.

6. Active Sonar System Testing and Development

Previous research into the application of active sonar to complement the PAM and to track non-vocal marine mammals (e.g. seals) around tidal turbines (Hastie, 2012), showed that high frequency multi-beam sonar can be used to reliably image seals in tidal environments and provide a potential means of tracking them around tidal turbines. Although the multi-beam sonar identified in the previous study is potentially an extremely useful tool, a number of limitations that would benefit from further work were highlighted resulting in a series of development recommendations being made (Hastie, 2012). Specifically, in terms of measuring fine scale behaviour of animals around tidal turbines, the multi-beam sonar did not provide data on the depth of the targets; the development of a 3D sonar system was identified as potentially being highly beneficial for measuring tracks of marine mammals around turbines. Furthermore, the automated marine mammal classification system developed in the previous study (Hastie, 2012) appeared highly conservative and resulted in a high proportion of false positive classifications; it was, therefore, recommended that new algorithms be developed and validated to improve the classification and reduce the need for post hoc processing.

The primary aims of the active sonar component of this study therefore sought to address these development requirements through the following tasks:

1. Develop a technique to track marine mammals in 3D using active sonar and test these in a tidally energetic environment;
2. Reduce uncertainty in the classification of marine mammals in multi-beam sonar data through the development of new automated classification algorithms.

Furthermore, there were a number of secondary aims that were identified during the current project:

3. Test the passive detection capabilities of multi-beam sonars for external acoustic signals including harbour porpoise clicks and VEMCO acoustic tags;
4. Test the imaging effects of different plastics that could potentially be used as a cowling for the multi-beam sonars.

6.1. 3D Marine Mammal Tracking using Multi-beam Sonar

To develop a sonar system to measure the 3D movements of non-vocal species (e.g. seals) around tidal turbines, a multi-beam sonar system previously identified as

having the potential to track seals in tidal environments was selected (Tritech Gemini 720id, Tritech International Ltd, Aberdeen, UK); this is a 720 kHz forward looking multi-beam sonar that is designed for detecting objects in the water column. It is effectively a 2D imaging system that allows detection and localisation of objects in the X-Y plane but does not provide information on the depth of the target. The image update rate of the sonar is between 7 and 30 Hz, the angular range resolution is 0.5° , and the range resolution is 0.8 cm. The horizontal and vertical swathe widths of the Gemini are 120° and 20° (-3 dB swathe) respectively and up to 4 heads can be operated simultaneously by synchronising the sonar pings.

The seal detection and tracking capabilities of the Gemini formed the foundation of a 3D tracking system. Specifically, dual sonar units were integrated and mounted in different orientations to test the optimum solution for tracking seals in 3D. Data were collected using two Gemini sonars deployed using a custom built sonar mount which allowed both the horizontal and vertical orientations of the sonars to be modified in the field (Figure 25). This was deployed from the side of a 7.5 m aluminium vessel and data were stored to external HDDs using a laptop PC located in the cabin of the vessel.

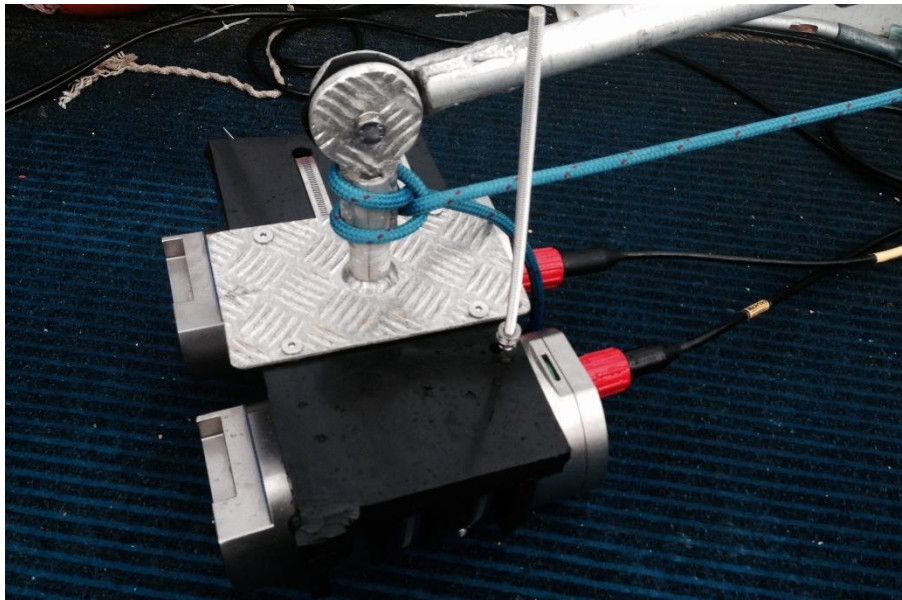

Figure 25: Photograph showing the two Gemini multibeam sonars mounted on a boat based mounting pole. Pivots on the pole allowed both the horizontal and vertical angles of each sonar to be modified prior to deployment.

Two methods of 3D tracking were trialled; one where the sonar swathes were mounted in a perpendicular orientation (Figure 26), and one where they were mounted in an offset parallel orientation (Figure 27). To calibrate both of these techniques, an inflatable vessel manoeuvred to a range of between approximately

20-40 m from the sonar and a grey seal carcass (1 m in length) was deployed underwater from the vessel using a custom built harness and a 50 m rope. The seal carcass had been frozen within hours of death and was defrosted 48 hours prior to the field trials. An OpenTag depth logger (Loggerhead Instruments, Sarasota, FL, USA) was attached to the seal to calibrate the depth estimates (pressure sensor in the logger had been factory calibrated to provide 0.5 cm depth resolution to 300 m) made using the sonars. In addition, a series of data of live seals diving freely in a tidally energetic environment were collected using each method.

6.1.1. Perpendicular Orientation Technique

The first approach was to mount the two sonars in perpendicular planes (i.e. one was mounted horizontally and the other vertically) such that there was a region of the water column where the sonar swathes overlapped (Figure 26). This approach was calibrated using a grey seal carcass which was raised and lowered through the sonar beams to the seabed (40 m). The seal carcass was easily observed as a temporally persistent, highly localised pattern of high intensity pixels in the sonar images. The X-Y locations of the seal carcass were measured manually every second on the horizontally mounted sonar using the software SeaTec (Version 1.18.11.12, Tritech International Ltd, Aberdeen, UK). The corresponding depth of the seal carcass was measured on the vertically mounted sonar by measuring the distance between the sea surface or seabed and the seal carcass (Figure 28).

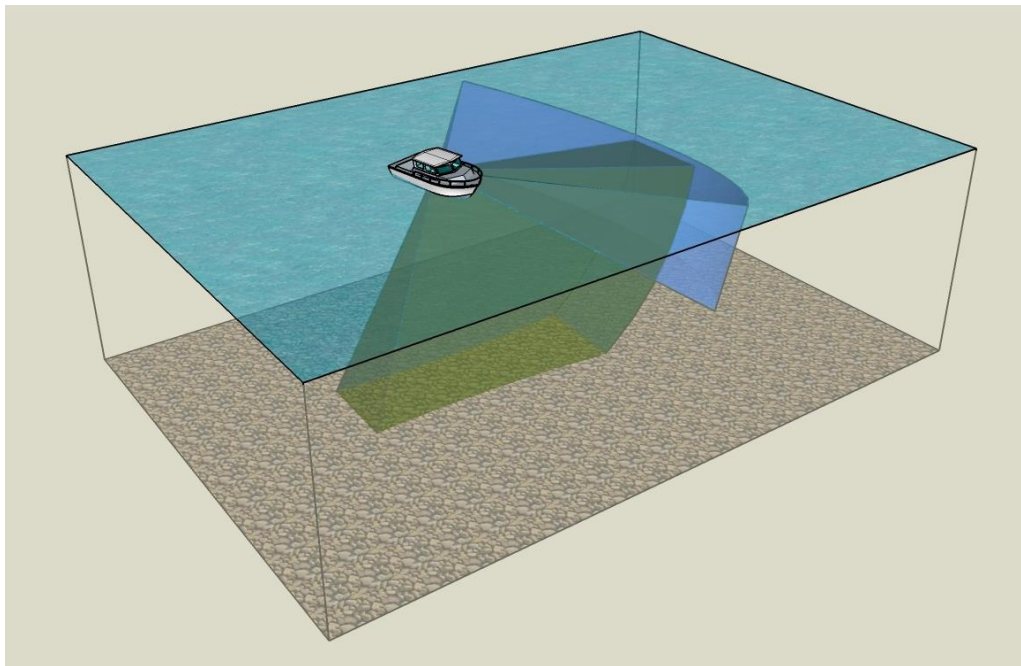

Figure 26: Schematic of the acoustic swathes (shown by the blue and green polygons) when the dual sonars were deployed from the research vessel in a perpendicular orientation.

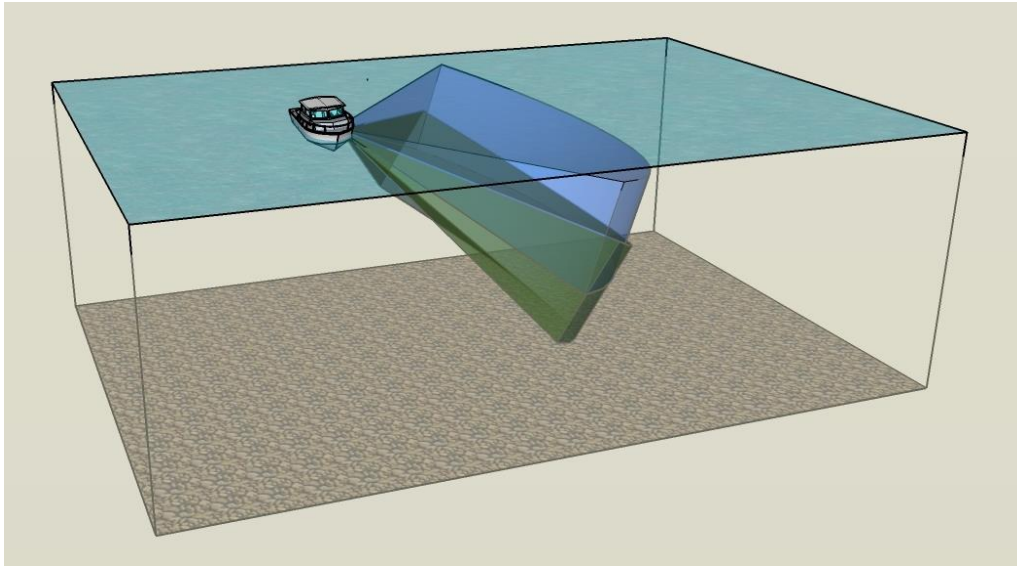

Figure 27: Schematic of the acoustic swathes (shown by the blue and green polygons) when the sonars were deployed from the research vessel in a parallel orientation; the sonars were offset by an angle of approximately seven degrees.

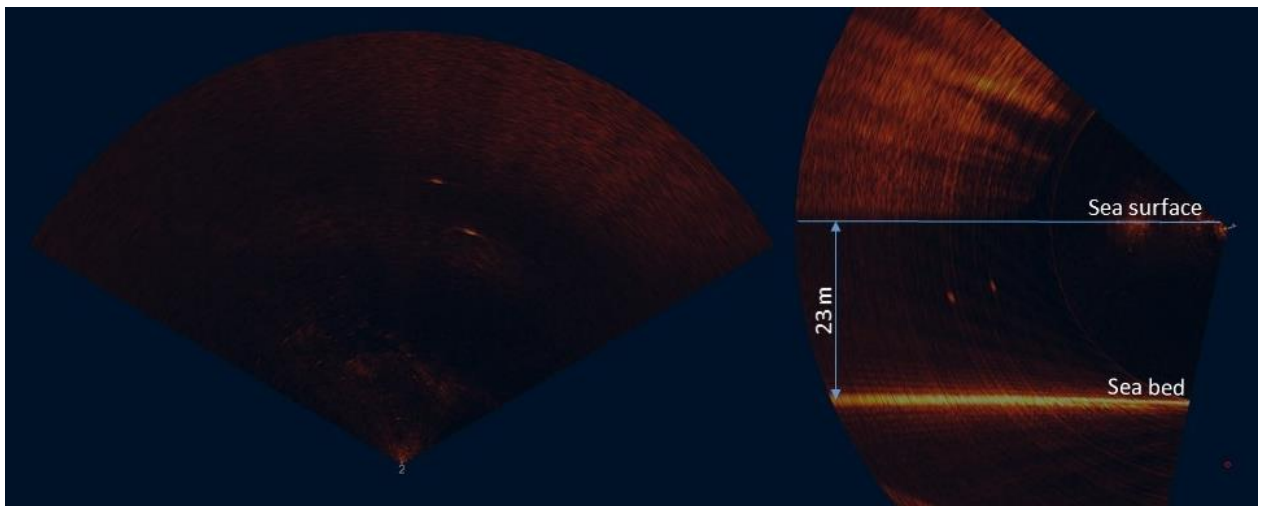

Figure 28: Example of the data when the sonars were deployed from the research boat in a perpendicular orientation. The figure shows the output from the horizontal sonar on the left and the vertical sonar on the right; two seals can be seen as temporally persistent, highly localised pattern of high intensity pixels in the sonar images.

The results of the calibration using the perpendicular dual sonars showed that the depth of the grey seal carcass could be relatively accurately measured as a distance from the sea surface. At ranges of between 15 and 42 m and for depths of between 0 and 34 m, the errors ranged from -3.0 to +4.9 m with a mean error of +0.8 m and a mean absolute error of 1.6 m (Figure 29).

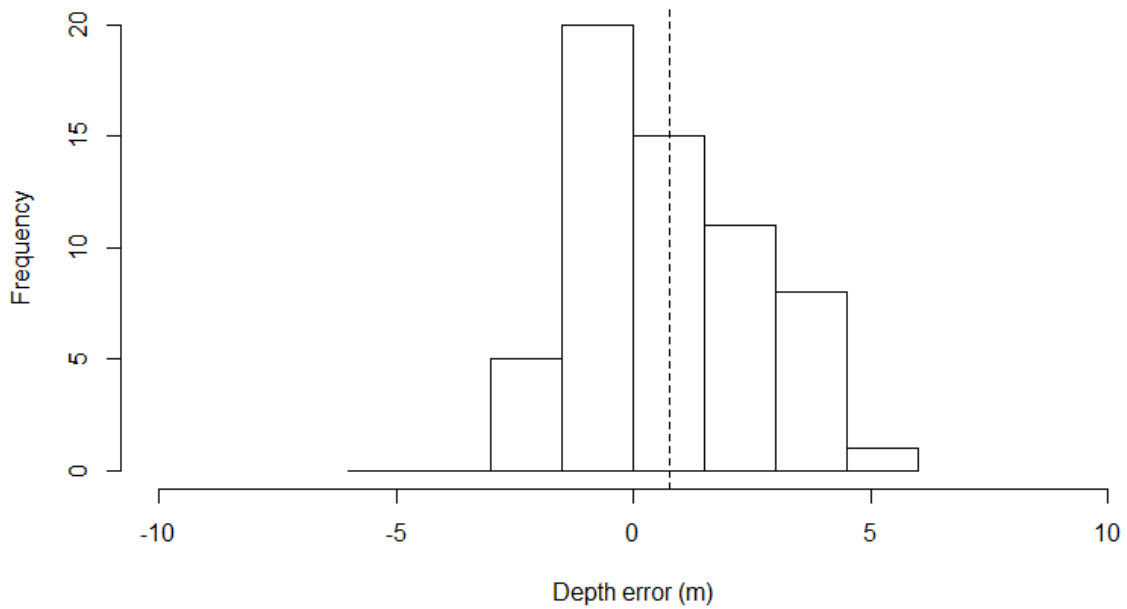
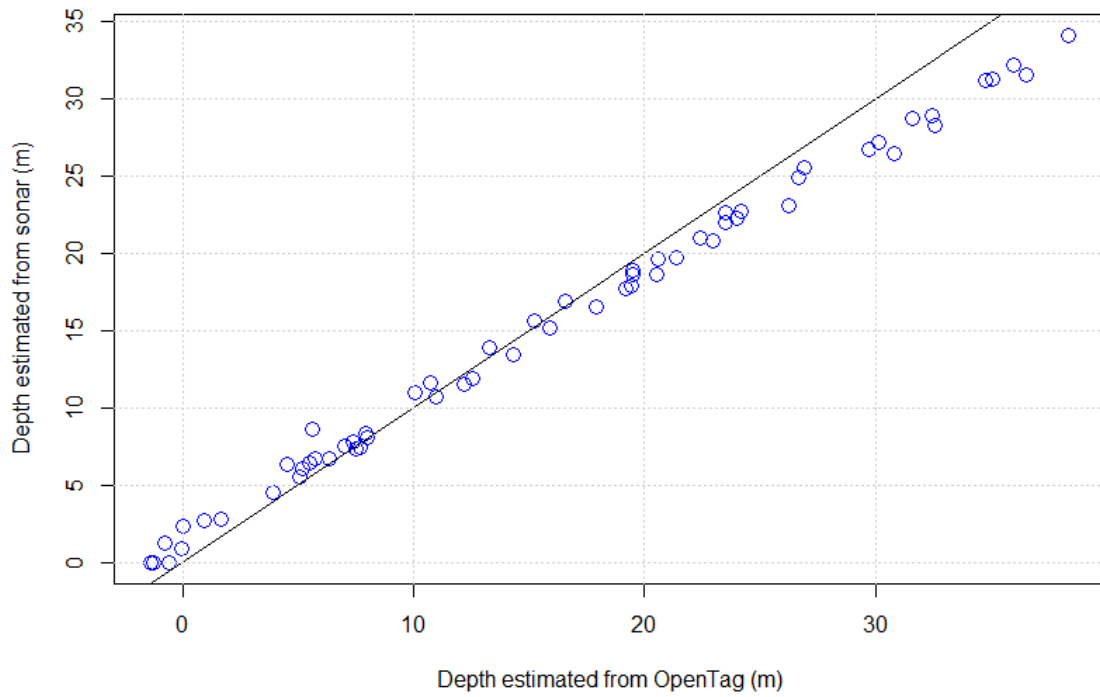

Figure 29: The upper panel shows the measured depths (using an OpenTag depth logger) of a grey seal carcass raised and lowered through the swathes of two 720 kHz multibeam imaging sonars plotted against the depths measured on the vertically orientated sonar; the diagonal line represents values where $y=x$. The lower panel is a histogram of the errors in depth estimation using the perpendicular sonars; errors ranged from -3.0 to +4.9 m with a mean error of +0.8 m (vertical dashed line) and a mean absolute error of 1.6 m.

6.1.2. Parallel Orientation Technique

A second approach to measuring the 3D locations of seals underwater was to mount both the sonars in the horizontal plane, but to offset one of them vertically such that there was a region of the water column where the sonar swathes overlapped (Figure 27).

This approach is based on the concept that if a multi-beam sonar is orientated horizontally, for a given range, the measured intensity of a seal will be at its maximum when it is located at the vertical apex (centre) of the beam; this will decrease as the seal moves vertically (up or down) away from the centre until it is no longer imaged by the sonar. Therefore, as a seal dives vertically down through the swathe of a multi-beam, the intensity of the seal measured on the sonar increases to a maximum as the seal passes the apex before declining as it dives further down through the beam. Given this, if two sonars are orientated horizontally but offset vertically, a seal diving down through each of the swathes will show this pattern of intensity on each respective sonar. However, at any particular depth, there will be a difference in intensity of the seal measured on each sonar as a result of the vertical offset between the sonars; by measuring the ratio of intensities between each of the sonars ($\text{Sonar 1 intensity} / \text{Sonar 2 intensity}$) it is possible to estimate the depth of the diving seal. A worked example of this is shown in Figure 30 and see Appendix B for further details.

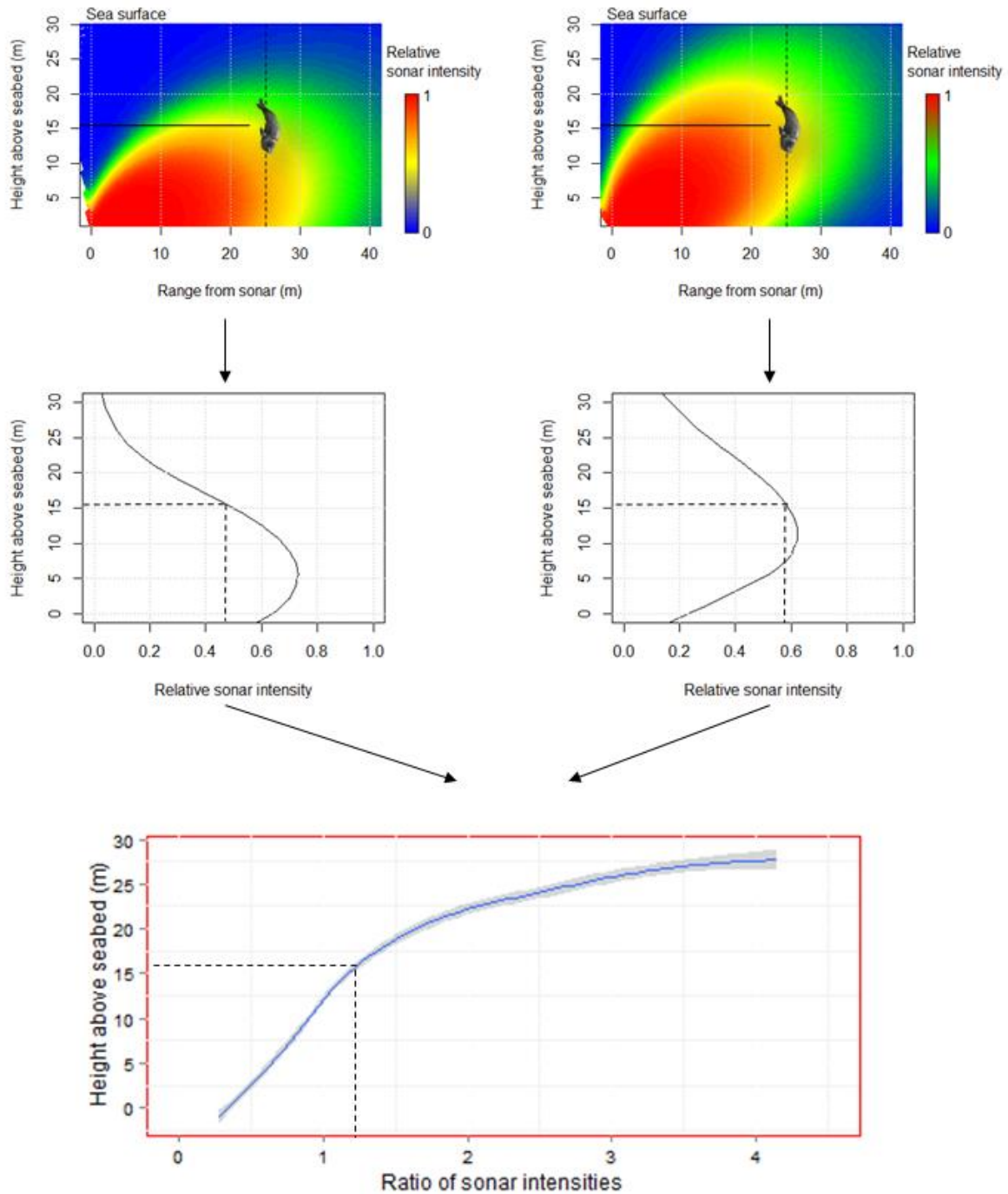

Figure 30: A worked example of the approach to calculate the depth of a seal using two multibeam sonars mounted in a horizontal orientation but offset vertically. The upper figures show the theoretical intensity of a seal measured from sonars located on the seabed and orientated at angles of 10 (left) and 27 degrees (right) upwards from the seabed; the vertical beam pattern was based on measurements of a seal carcass (Appendix B). A simulated dive of a seal down through each of the beams from the sea surface to the seabed at a range of 25 m from the sonars is shown by the dashed line. The middle figures illustrate the theoretical intensity of the seal measured on each of the sonars during this simulated dive (solid line); the dashed lines illustrate an example of the intensity on each sonar (left~0.47, right~0.58) when the seal is located 15 m above the seabed. The lower figure shows the ratio of theoretical intensities between each of the sonars (right sonar intensity/left sonar intensity) during the seal dive with the example ratio (dashed lines: 1.26) when the seal is located 15 m above the seabed.

As described in Section 6.1.1, a grey seal carcass with an OpenTag depth logger was used to calibrate this method. The results of this showed that the depth profiles of the grey seal carcass could be accurately plotted by measuring the ratio of intensities between the sonars and smoothing the resulting predicted depths using a cubic spline smoother (see Appendix B for details). At ranges of between 27 and 40 m and for depths of between 0 and 20 m, errors ranged from -2.6 to +4.3 m with a mean error of +0.7 m and a mean absolute error of 1.5 m (Figure 31). It is important to highlight that some of the error in depth estimation (particularly with this offset horizontal technique) will be as a result of vessel movement during data collection, and it is anticipated that the errors will be reduced if the sonars are mounted on a static platform.

When considering the best 3D tracking approach, it is important to consider, not only the magnitude of the errors, but also the pros and cons of the data produced by each. For example, although the perpendicular technique is relatively straightforward compared to the horizontal approach, it is likely that the most effective location to deploy dual sonars in the perpendicular orientation would be upstream or downstream of the turbine. This has inherent limitations in that detectable marine mammal movements will be limited to one side of the turbine which will either be upstream or downstream depending on the direction of the tide. The opposite side of the turbine will always be masked by the turbine itself. The horizontally mounted sonar system is analytically more complex but offers the advantage that it can be located to the side of the turbine which should allow the 3D movements of individual seals to be measured both upstream and downstream of a tidal turbine. It is, therefore, proposed that the offset parallel orientation provides better data to track seals around the operating turbine.

To test the capabilities of the offset parallel orientation to track the 3D movements of live harbour seals in a tidally energetic location, data were collected between 10 and 12 June 2015 in a narrow, tidally energetic channel on the west coast of Scotland that had previously been shown to have high densities of harbour seals (Kyle Rhea: 57°14'8.10"N, 5°39'15.25"W). The channel runs from north to south, is approximately 4 km long, and is 450 m wide at its narrowest point. Water depths within the channel are less than 40 m. Tidal currents within the channel can exceed 4 m s^{-1} at peak flow (Wilson *et al.* 2013) with water moving in a general northerly direction during the flood tide and a southerly direction during the ebb.

A total of 56 seals were tracked within Kyle Rhea using the horizontally mounted dual sonars. The vessel manoeuvred around the channel but focused on areas previously identified as being of high-use (Hastie *et al.*, in review). As described

above, the seals were easily identified as highly localised patterns of temporally persistent, high intensity pixels in the sonar images (Figure 32 and Figure 33); however, for the purposes of this analysis, only sonar targets where identification was confirmed by a visual observer on the vessel were used.

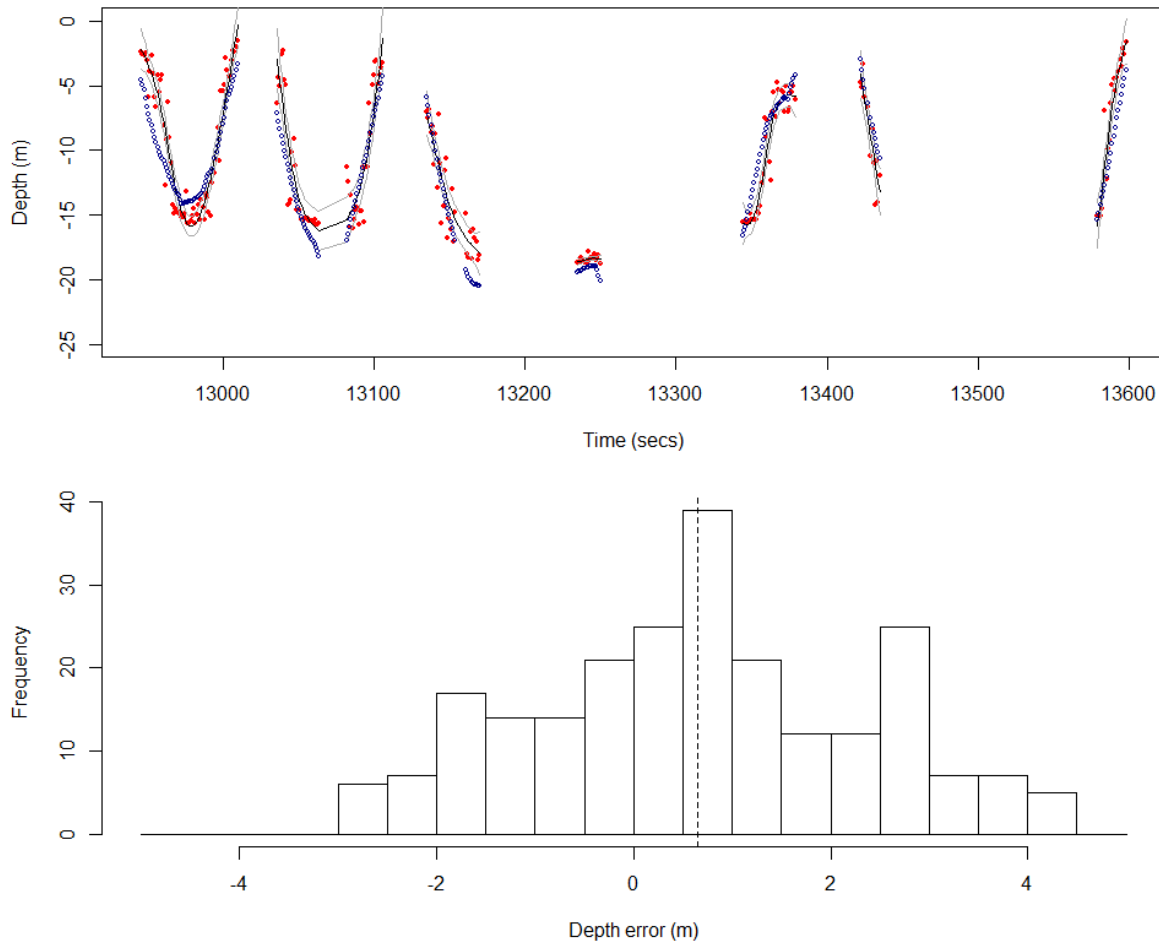

Figure 31: The upper panel shows the measured depths (using an OpenTag depth logger: blue points) of a grey seal carcass raised and lowered through the swathes of two 720 kHz multibeam imaging the sonars; the raw predicted depths (using the ratio of intensities approach: red points) and modelled depths (black line) with 95% CIs (grey lines) made using a cubic spline smoother are also shown. The lower panel is a histogram of the errors in depth estimation using the intensity ratio and cubic spline smoother approach; errors ranged from -2.6 to +4.3 with a mean error of +0.7 m and a mean absolute error of 1.5 m.

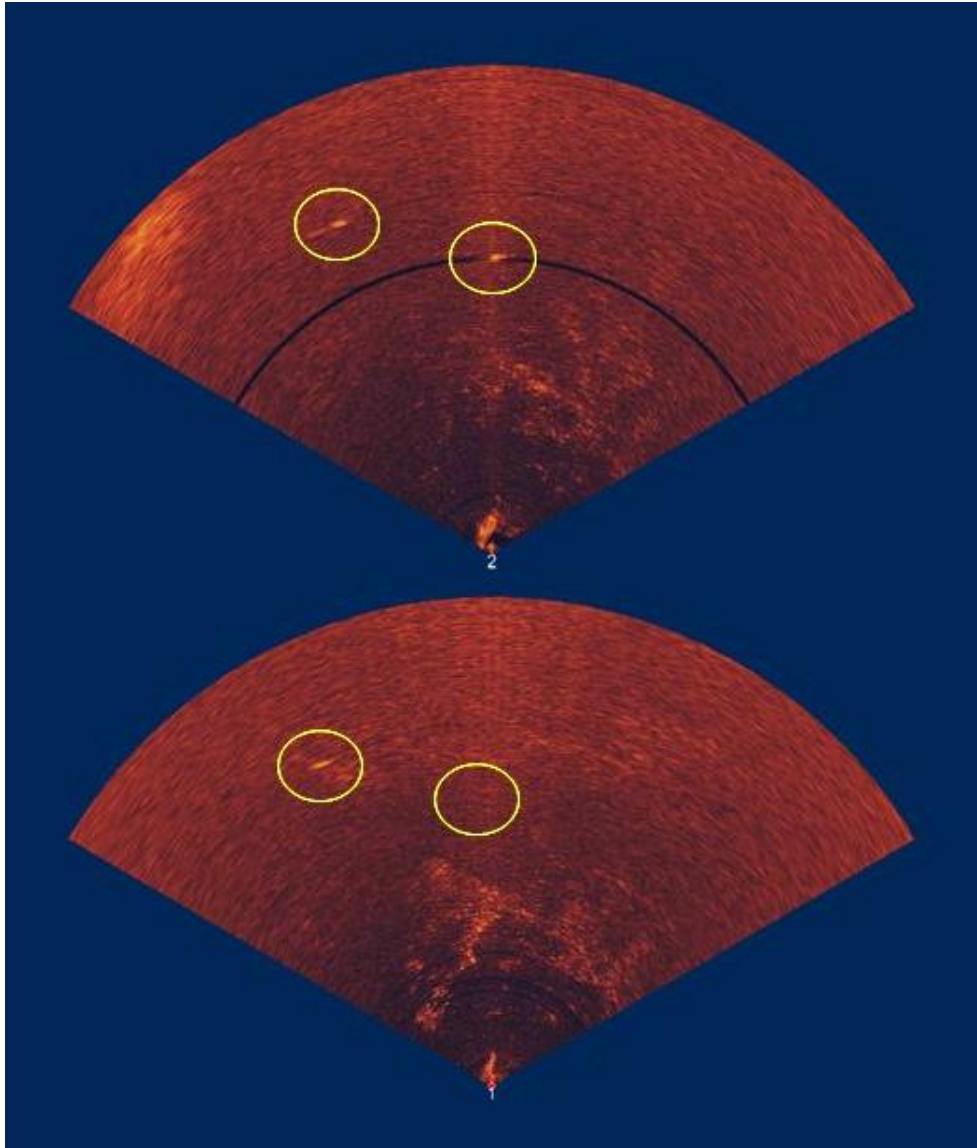

Figure 32: Example of a snapshot of sonar data collected within a narrow tidal channel off the west coast of Scotland. Two harbour seals at a range of approximately 30 metres (confirmed through visual observations at the surface) can be seen as distinct targets. In the upper sonar, two seals can be seen whilst only one of them can be seen in the lower sonar; this suggests that one seal is close to the surface whilst the other is mid-water.

The X-Y locations of seals were measured at one second intervals manually using a marker tool in the sonar software. The depth of the seals was estimated using the intensity ratio between each sonar and the method described above. Each seal track was geo-referenced in 3D within the channel using a combination of these X-Y locations and dive depth estimates, together with data from a GPS data logger on the boat and the angle of orientation of the sonars from an OpenTag fixed to the top of the sonar mounting pole (Figure 34).

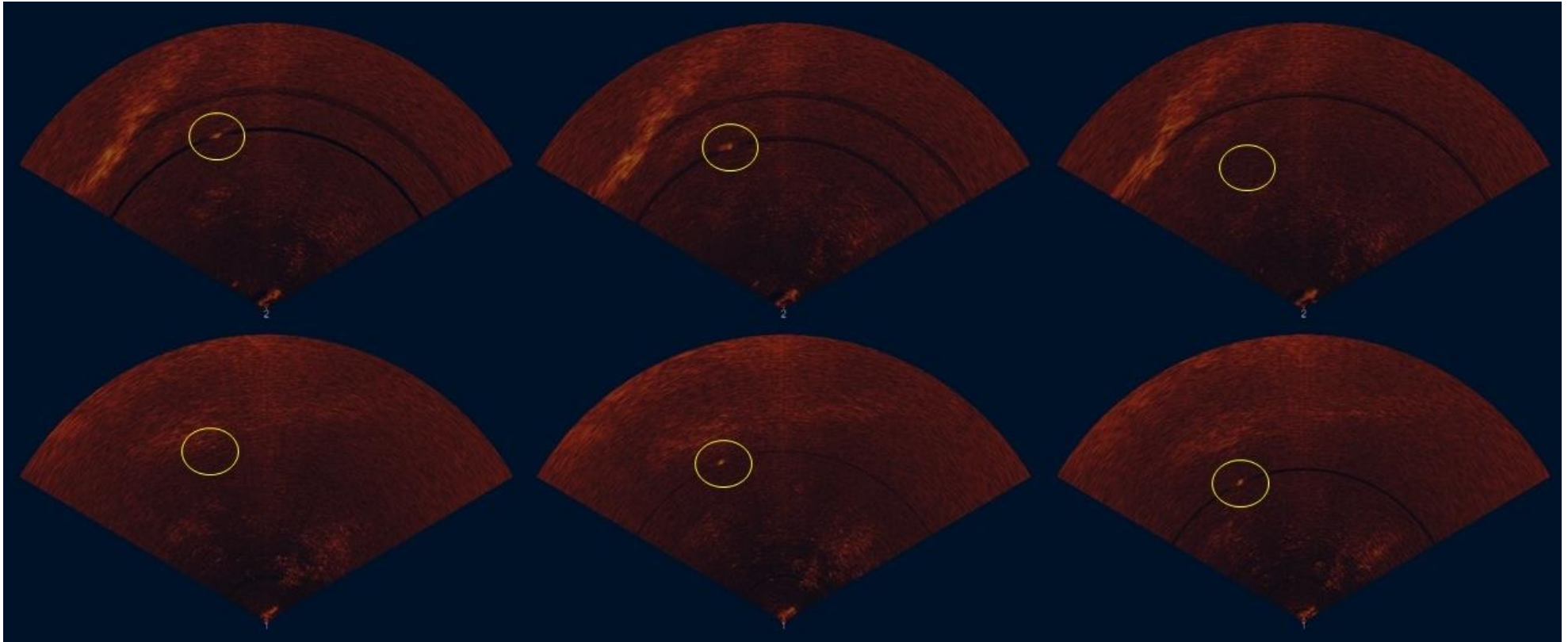

Figure 33: Example of the data over a period of ten seconds when the sonars were deployed from the research boat in an offset parallel orientation. The figure shows the output from the upper sonar at the top and the lower sonar at the bottom at 0 (left), 5 (middle), and 10 (right) seconds. A harbour seal can be seen at a range of approximately 30 m in the upper sonar only at 0 seconds, both sonars at 5 seconds, and the lower sonar only at 10 seconds. Further, there was little movement in the X-Y plane over this time indicating that over the 10 second period the seal dived vertically from the surface down through the water column.

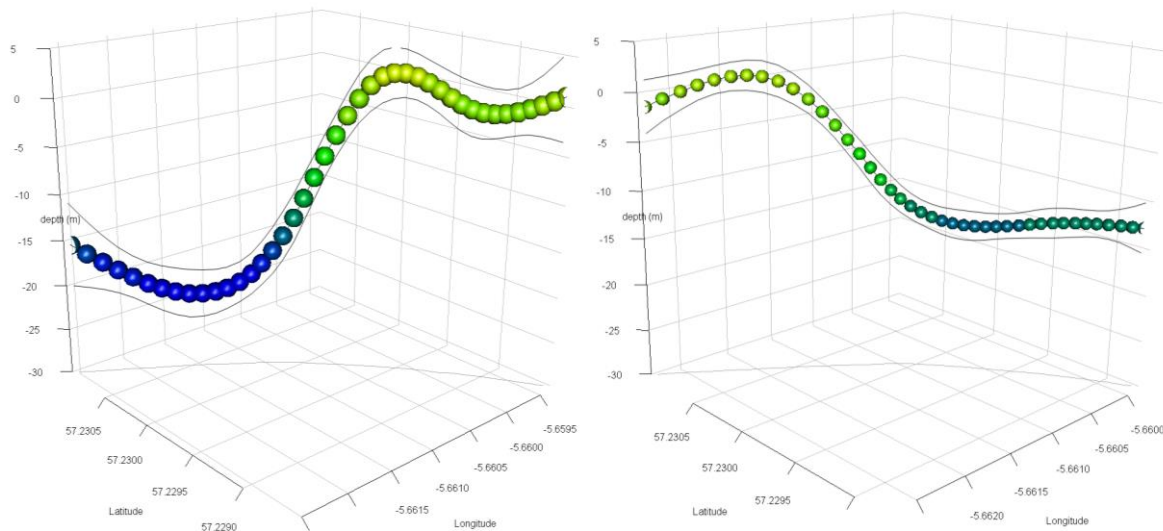

Figure 34: Examples of the 3D movements of harbour seals tracked underwater in a tidally energetic channel using the dual sonar system orientated horizontally. The points represent modelled locations at one second intervals, colour coded by depth, and the black lines represent the 95% CI's of the modelled dive depths. The grey line at the base of the plot represents the X-Y track of the seal for illustrative purposes.

As described above, it is proposed that the offset parallel orientation is used to track seals around the operating turbine. Given this, several key pieces of information are required to convert locations in 'sonar-space' to 'turbine-space':

- 1) the relative height of the sonars relative to the turbine nacelle;
 - It is anticipated that this will be obtained via detailed information on the seabed depths and accurate micro-siting of the sonar platform during deployment;
- 2) the rotation of the sonars in the yaw axis;
 - It is anticipated that this will be obtained via accurate micro-siting of the sonar platform during deployment and can potentially be confirmed from sonar data (imaging the turbine) during installation;
- 3) the rotation of the sonars in the pitch and roll axes;
 - It is anticipated that a pan and tilt mechanism with an integrated 3D accelerometer/magnetometer will be used to level the sonars in these axes.

6.2. Development of Automated Marine Mammal Classifiers

Previous marine mammal work with the Gemini multi-beam sonars aimed at developing a sonar system to provide a behavioural monitoring tool for marine mammals around marine energy devices (Hastie, 2012). As part of this, sonar data

for a range of marine mammal species were collected to develop efficient classification algorithms to reduce data volumes and provide an identification of individual targets. The result of this development program was a user interface for the Gemini multi-beam sonars with an optional module (SeaTec) for the automated detection and tracking of marine mammals. This uses information on size, shape and movement characteristics to determine valid marine mammal targets. However, subsequent validation work with seals has shown that SeaTec is highly conservative in that it is good at detecting seals, but also produces a relatively high number of false positives. This is potentially advantageous from a tidal turbine marine mammal monitoring perspective, where encounters are anticipated to be relatively infrequent; however, it potentially leads to excessive levels of post hoc manual validation of targets. The aim here was, therefore, to improve the data reduction without significantly reducing the probability of detecting marine mammals. This was carried out by refining the marine mammal classifications through a series of analyses of SeaTec data outputs.

As described in Section 6.7.1, Gemini multi-beam sonar data were collected from a seabed mounted platform (HiCUP) deployed in Kyle Rhea at a depth of approximately 15 m on 1 August and retrieved on 5 August 2015. Seals were imaged by the sonar frequently during the data collection periods and confirmed through visual observations of seals from the data collection vessel. The SeaTec detection and tracking software was run post hoc to provide a dataset of seal tracks for the marine mammal classification analyses. All of the visually confirmed seals were detected and tracked (71 tracks) by the pre-development software. Relatively small scale turbulent hydrographic features were also frequently evident in the sonar data at particular states of the tide. These were temporally persistent in the sonar data, often for periods of several tens of seconds. These were frequently detected as potential marine mammals and tracked by the SeaTec software (101 tracks) and were included in the dataset for the classification analyses.

Further information related to each target detection was provided using a version of the SeaTec customized for this analysis to provide a broad range of parameters associated with each detection. This included range from the sonar, kinematic information (e.g. speed and trajectory in the X and Y planes), and detailed information on the size and shape of each detection. The latter was recorded as a series of target intensity matrices which were saved as *.txt files; these were numeric matrices of the acoustic intensities of the detected target within a defined bounding box (Figure 35).

A total of 161 targets detected by SeaTec were used for this analysis; 65 of these were seals and 96 were non-seal (Figure 35). Non-seal targets were generally small scale turbulent hydrographic features (and items of debris; e.g. seaweed) which appeared as temporally persistent features in the sonar data, often for periods of several tens of seconds.

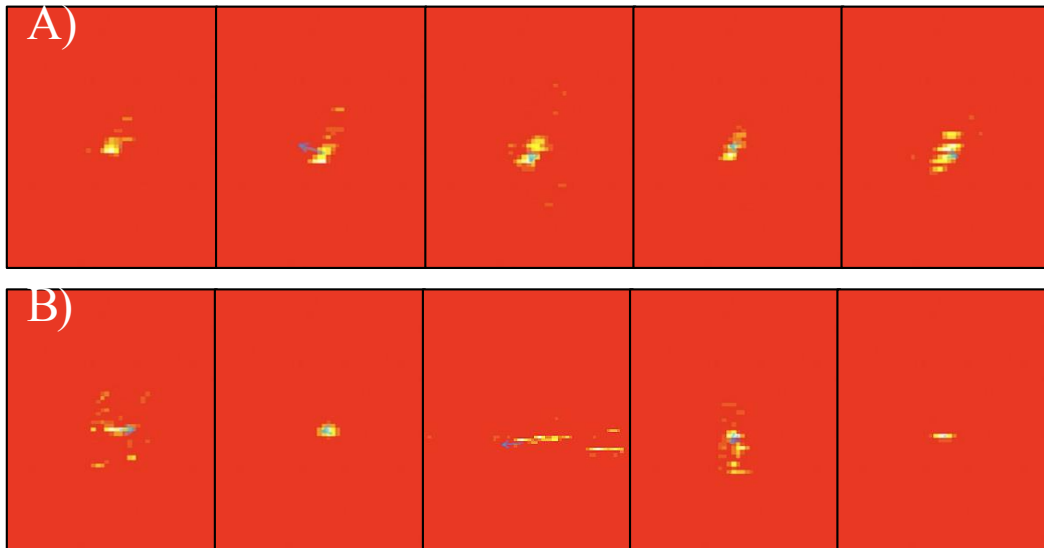

Figure 35: Examples of underwater sonar target images with pixel intensities (blue arrows show the velocity of moving targets). A) sequence of images for one seal over five consecutive frames. B) sample images from five different non-seal targets.

A total of 110 candidate features of the targets were extracted to be used in the classification algorithm. This included the temporal persistence of the target, summary statistics on the movement of the target (distance travelled, angle of movement, proportion of static frames), the shape of the target (length, area, perimeter, and their ratios), and pixel intensity of the targets. Shape features were extracted from the intensity matrices using the R package “raster” (Version 2.4-15). The mean/median, standard deviation, minimum and maximum was computed for each feature. In addition, spectral properties of all features except persistence were derived (spectral density, frequency and amplitude of the first and second peaks). The spectral properties describe changes of the features through time and are extracted from spectrograms generated by Fourier transforms of the features (Cryer and Chan, 2008). For instance, the shape of a seal may change cyclically as it swims; this would appear as one peak frequency in the spectrogram of one or more shape feature. Spectral features were extracted using the R package “stats” (Version 3.2.1). Finally, features with near-zero variance and those that were highly correlated to other features ($r > 0.9$) were filtered out using the R package “caret” (Version 6.0.64). Eighty-three features remained and were scaled prior to use in the analysis.

A Kernel Support Vector Machine, SVM (Hastie *et al.*, 2009) was fitted to the data to classify targets (seal vs non-seal) using the R package “kernlab” (Version 0.9-22). SVMs fit boundaries (support vectors) between classes in 2D space (pairs of features). The number of support vectors can be increased by increasing the parameter “C” (cost of misclassification), and yield a better fit to the data. However, using too many support vectors can result in over-fitting to the data and loss of generality. In order to avoid over-fitting, the parameter “C” was selected by minimising cross-validation error. A 20-fold cross-validation was performed for each parameter value: the data were split in 20 sub-samples, after which the algorithm was fitted using 19 sub-samples and validated using the remaining one. This was repeated 20 times using each sub-sample in turn for validation. The cross-validation error was thus the mean error rate in the 20 validation sub-samples. The algorithm was fitted with parameter “C” of $10^{(-1 \text{ to } 6)}$, and 100 times with each parameter value to estimate the uncertainty of the cross-validation error rate. As there were more non-seal targets than seal targets, a balanced sample was generated using the sampling algorithm “SMOTE” (Chawla *et al.*, 2002). A new sample was generated using the R package “unbalanced” (version 2.0) for each of the 100 iterations.

Table 10

Fitting the parameter “C” for the kernel Support Vector Machine algorithm. Values for the cross-validation (20-fold) and the number of support vectors are the mean and SD for 100 iterations. The selected model is shown in bold.

Parameter “C”	Cross-validation error		Number of support vectors	
	Mean	(SD)	Mean	(SD)
0.1	0.61	(0.016)	260	(0)
1	0.12	(0.018)	166	(6.4)
10	0.067	(0.014)	119	(6.0)
100	0.059	(0.012)	111	(6.9)
1000	0.057	(0.012)	110	(5.9)
10000	0.059	(0.012)	110	(6.8)
100000	0.059	(0.012)	111	(6.4)
1000000	0.058	(0.012)	112	(6.1)

The algorithm with parameter C = 1000 was selected as the best fitting; it yielded a mean cross-validation error of just under 6% using 110 support vectors (Table 10). The classification accuracy for the entire dataset was 100% for seal targets and 92% for non-seal targets (Table 11), with an overall accuracy of 95% (SD=1.6%).

Table 11

Classification of the entire dataset (161 targets) using the fitted kernel Support Vector Machine algorithm. Values in the confusion matrix are mean (SD) frequencies of the 100 iterations.

	Classified Seal	Classified Non-seal
Confirmed seals (N=65)	65 (0)	0 (0)
Non-seal targets (N=96)	7.7 (2.5)	88.3 (2.5)

These results show that it is possible to discriminate between seals and non-seals in Gemini multi-beam sonar data with a relatively high degree of accuracy. The algorithm used correctly classified all the confirmed seal targets but misclassified a small percentage of non-seal targets (~8%) as seals.

If this result holds with future datasets, the analytical approach appears to be an effective means of detecting and classifying seals. However, it is important to highlight that the number of non-seal targets is likely to be far greater than the number of true seals targets in a tidal turbine monitoring application so that the 8% misclassification of non-seal targets could result in a relatively high number of false positive detections. Nevertheless, this approach appears successful in significantly reducing the number of false positive seal targets so that Gemini datasets collected during tidal turbine monitoring can likely be reduced to manageable volumes.

The importance of individual features in the classifier is challenging to extract because kernels are fitted in multi-dimensional space (combinations of features). However, to get a sense of which features are important, the performance of classifiers were compared and fitted to different groups of features: all, only spectral, all except spectral, only pixel intensity, only shape, and only movement (Table 12). This comparison shows that the shape and non-spectral movement features result in the lowest cross validation error.

Table 12

Performance of kernel Support Vector Machine classifiers fitted with different subsets of features (mean and SD of 20-fold cross-validation error over 100 iterations). N is the number of features included in each classifier after excluding near-zero variance and highly correlated features. The mean (SD) number of support vectors is also shown to indicate the complexity of the classifier.

Features	N	Cross-validation error		Number of support vectors	
		Mean	(SD)	Mean	(SD)
All	83	0.057	(0.012)	110	(5.9)
Non-spectral	26	0.073	(0.014)	101	(5.5)
Spectral only	57	0.180	(0.013)	129	(7.3)
Pixel intensity	23	0.179	(0.030)	158	(7.9)
Shape	36	0.091	(0.017)	100	(5.8)
Movement	23	0.072	(0.015)	93	(5.0)
- <i>spectral</i>	13	0.242	(0.016)	139	(4.4)
- <i>non-spectral</i>	15	0.086	(0.015)	104	(4.8)

Further development of the classifier (with more validated targets) could potentially increase the accuracy and further reduce the number of false positive detections. While the kernel SVM algorithm yielded a high accuracy in predictions, it uses kernels in multidimensional space, making the results difficult to interpret. A different type of analysis might be more appropriate to narrow down which features are important. Comparison of the classifiers using different subsets of features suggests that simple summary statistics about the movement of targets may be sufficient to classify seals. The next step is to integrate this analytical approach into the SeaTec software such that classification can be run in real time.

6.3. Porpoise Click Detection with the Active Sonar

Additional target classification information is potentially available through passive acoustic information received by the Gemini sonars. Specifically, high frequency external sounds (e.g. echo-sounders) are often detected on the Gemini sonars as 'crosstalk' (seen as regular flashes of intensity in the data). Therefore the high frequency clicks of harbour porpoises were tested to investigate whether they could also be detected on the sonars as a potential additional means of validating sonar targets. A high frequency playback system (described in Section 5.2.3) was used to play the echolocation signals of harbour porpoises in the vicinity of the Gemini

sonars. However, results showed that, even within a few metres, the porpoise clicks were not observable in the sonar data.

6.4. VEMCO Acoustic Tag Detection with Active Sonar

As above, the acoustic signals produced by VEMCO acoustic tags (Section 5.1.2) had the potential to be detected by the Gemini sonars as 'crosstalk'. Therefore, a VEMCO acoustic tag was deployed in the vicinity of the Gemini sonars to test whether they could be detected by the sonar. However, results showed that, even within a few metres, the acoustic output of the tag was not observable in the sonar data.

6.5. Cowling Tests with Active Sonar

Given the hydro-dynamically aggressive nature of tidal environments, it was deemed prudent to consider providing as much protection to the sonar housing as possible without compromising imaging ability. Therefore, the effects of the addition of an acoustically transparent polyethylene cowling (the same as that proposed for the PAM hydrophones) over the Gemini sonars was tested to see if there were any effects on the imaging capabilities of the sonar. A series of detection tests were carried out using a target (air filled bottle) deployed two metres below the inflatable boat at a range of approximately 30 m from the sonar. The polyethylene cowling was then placed over the sonar and the images of the target compared. Results showed that in each case, there was an appreciable decrease in the target intensities with the addition of the cowling (Figure 36). This suggests that imaging marine mammals is likely to be affected by the addition of a cowling using this material. Given these results and through further discussions with sonar engineers it is suggested that any additional protection provided to the Gemini sonar units (in the form of a cowling or frame) should not cover the transmit or receiver transducers.

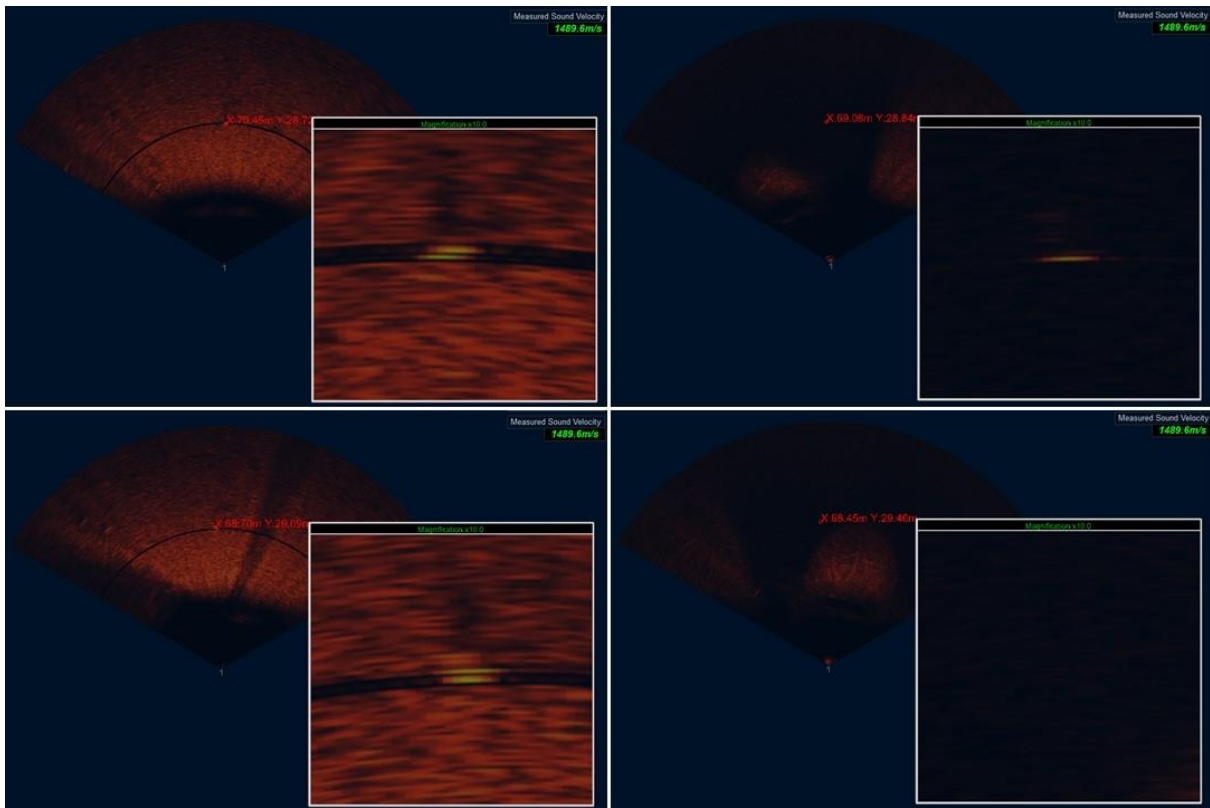

Figure 36: The effects of a polyethylene cowling on the imaging capabilities of the Gemini sonar. The figure show the magnified images of a target deployed approximately 30 metres from the sonar without (left panels) and with (right panels) the cowling placed over the sonar.

6.6. Imaging Capabilities of Other Species with Active Sonar

In addition to the data collection of seals described above, data for a range of other species were collected opportunistically during the study. This included 1) harbour porpoises; 2) bottlenose dolphins; 3) razorbills (*Alca torda*), which are relatively small ($\approx 0.25\text{m}$ in length), highly mobile targets, that had distinctive trails of turbulence or bubbles streaming behind them; 4) Northern gannets characterised by a distinctive area of turbulence or bubbles (where the bird entered the water) and a trail of turbulence or bubbles leading away from it, and 5) a number of unidentified fish species. These were each confirmed through a combination of visual observations (species 2, 3, 4 and 5) and passive acoustic monitoring (species 1 and 2). Active sonar images for these other species, except the unidentified fish, are shown in Figure 37.

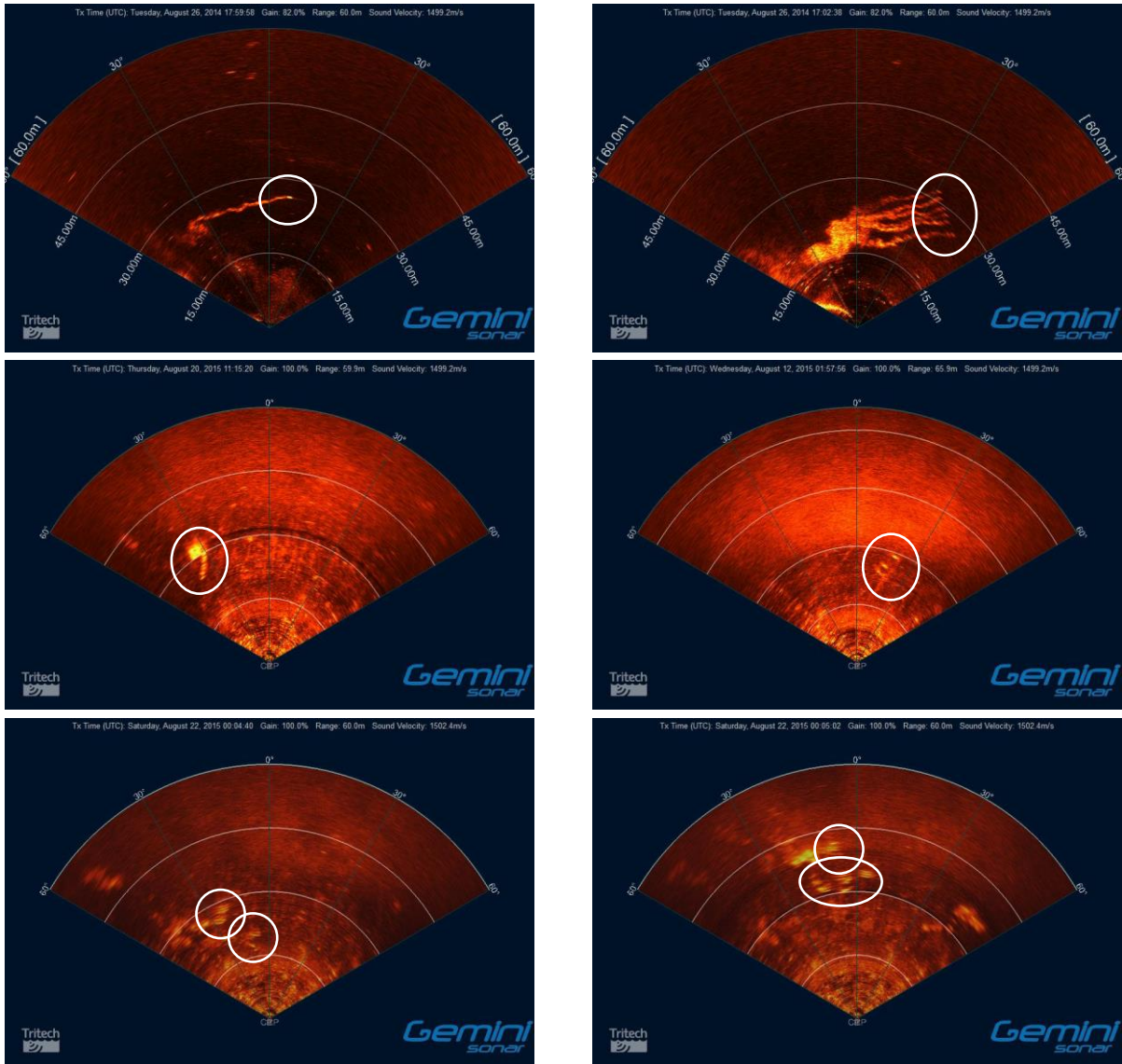

Figure 37: Images of other species detected using the Gemini 720id multi-beam sonar. The species are razorbills (upper left and upper right), a diving Northern gannet (mid left), harbour porpoises (mid right), and bottlenose dolphins (lower left and lower right). Each sonar swath extends to a distance of 60 m.

6.7. Integrating Tracking Sensors on Seabed Mounted Platforms

6.7.1. Sonar HiCUP Deployment A – Imaging Marine Mammals in a Tidal Channel

A single HiCUP with dual Gemini 720 kHz multi-beam sonars mounted in a parallel horizontal offset orientation (as described in Section 6.1.2) on a custom built manual pan and tilt mechanism (to control the pitch and roll axes), was deployed in Kyle Rhea in August 2015 (Figure 38). The primary aims of this deployment were to:

1. Investigate the imaging capabilities of the sonars from a seabed mounted perspective (investigate the effects of tidally induced turbulence on the sonar data);
2. Collect data to develop and validate the marine mammal algorithms (sonar data in combination with visual observations of marine mammals);
3. Collect data to validate 3D marine mammal tracking from a seabed mounted perspective.

The Sonar HiCUP was attached to a small surface marker buoy so that its location could be determined during data collection purposes. A secondary one ton anchor which was located approximately 30 m inshore from the HiCUP, was connected via a poly-steel rope riser to a mooring buoy at the surface (Figure 39) where a 7.5 m aluminium vessel could be moored to collect data. The sonars were connected to a 150 m extension cable with wet-mate terminations at each end and loosely attached to the secondary anchor and riser; these could be connected to the topside electronics of the sonar (Gemini 72V VDSL Adapter) on the vessel for data collection. The Sonar HiCUP was deployed from 1 to 5 August, 2015, on the seabed (rocky with small boulders) towards the western shore of Kyle Rhea at a depth of approximately 15 m (above Admiralty chart datum) using the survey vessel MV *Toohey*. A diver manually adjusted the pan and tilt immediately after deployment to ensure the sonars were level (Figure 40). For deployment at the tidal turbine site, it is anticipated that a pan and tilt mechanism will be remotely controlled rather than requiring a diver or ROV to manually adjust.

The data collection vessel was moored on the buoy and data were collected during daylight flood tides over this period (seals are most active on the flood tide in this area). Visual observations of seals (and other species) at the surface were also made from the vessel to provide a validation of sonar targets. Throughout these periods, the sonar system proved to be highly reliable and data were collected continuously throughout the monitoring periods. However, as a result of water ingress into one of the subsea connectors, only one of the two sonars was operational during this deployment and unfortunately this precluded the validation of the 3D marine mammal tracking techniques from a seabed mounted perspective. The leak was rectified for the subsequent Sound of Sleat deployment. Data were collected over most of the flood tide period; however, at peak flow ($>3 \text{ ms}^{-1}$) difficulties associated with maintaining the vessel on the mooring in the high current meant that there were short breaks (around 90 minutes) in monitoring over these periods. A total of 76 GB of sonar data were collected during these periods.

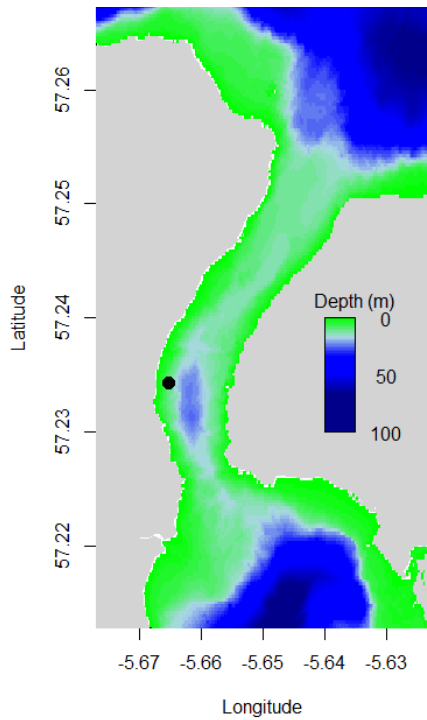

Figure 38: Hi Current Underwater Platform (HiCUP) with dual sonar configuration in Kyle Rhea. The left panel shows the location of the HiCUP in the channel and the right panel shows it being deployed from the survey vessel.

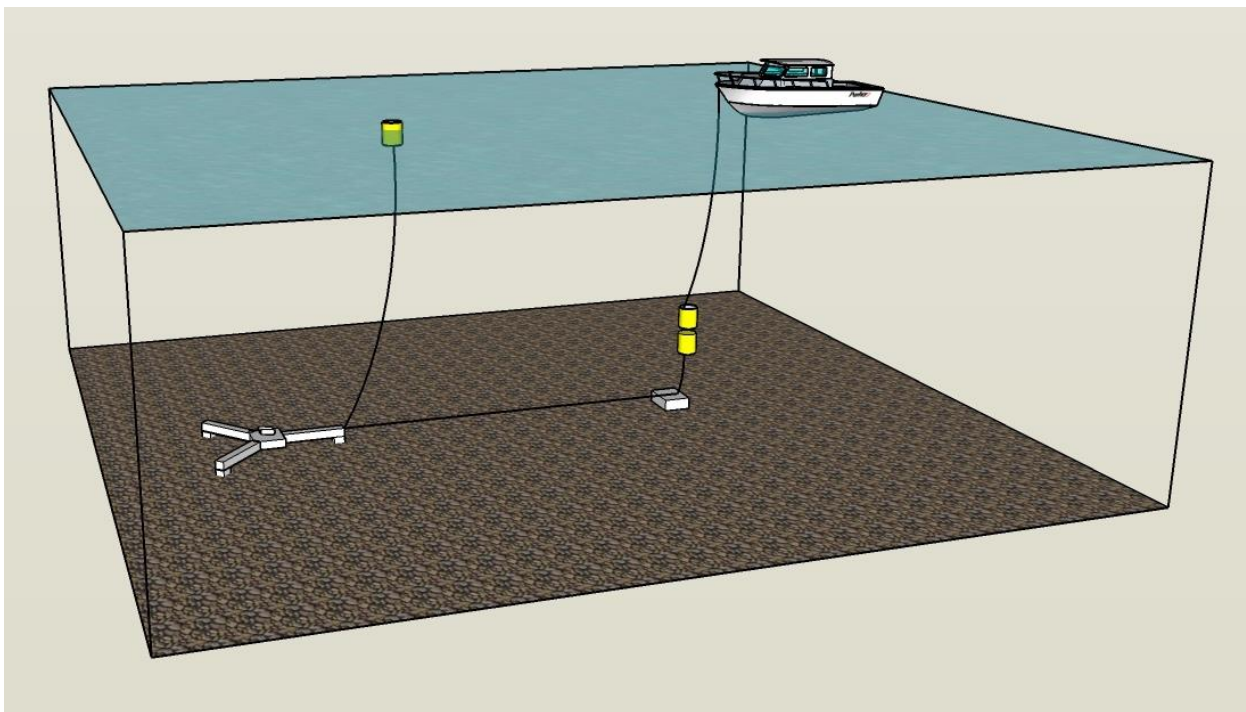

Figure 39: Schematic of the sonar HiCUP mooring deployed in Kyle Rhea showing seabed mounted HiCUP, the secondary anchor, the small HiCUP locating surface buoy, and the data collection vessel.

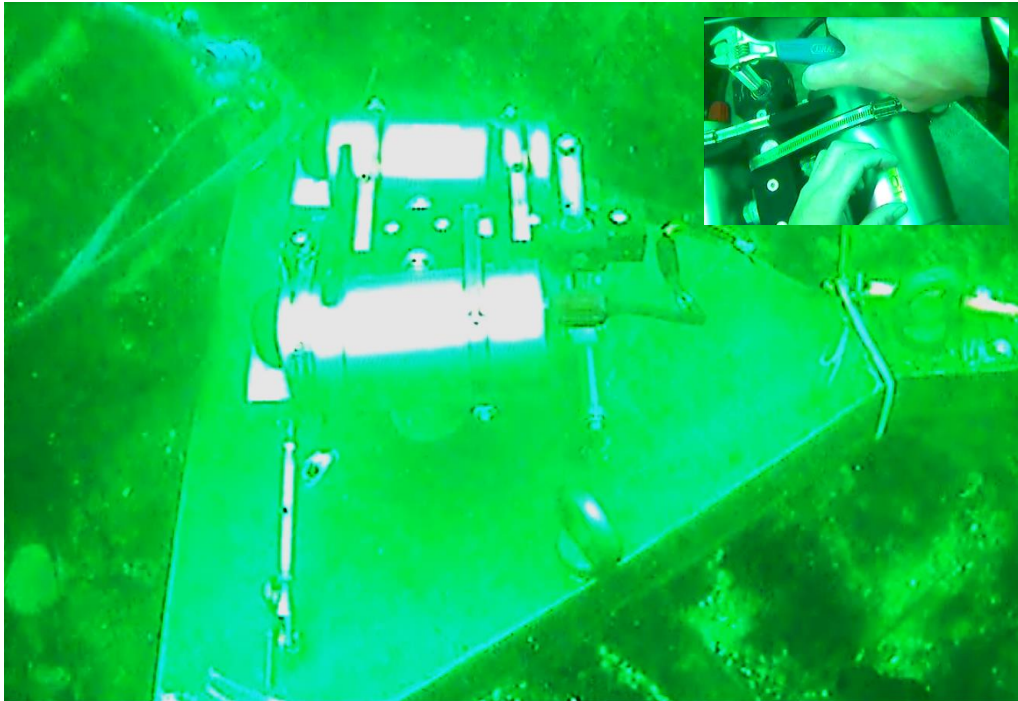

Figure 40: Image from the diver helmet mounted camera showing the dual sonars deployed on the HiCUP during installation in Kyle Rhea (main) and the diver adjusting the manual pan and tilt mechanism (inset) to level the system.

Seals were sighted frequently during the data collection periods in Kyle Rhea and these were also imaged by the sonar. The pre-algorithm development detection and tracking software (SeaTec) was run post hoc to provide a dataset of seals for the marine mammal classification analyses. All of the visually confirmed seals were detected and tracked (71 tracks) by the pre-development software.

Relatively small scale turbulent hydrographic features were also frequently evident in the sonar data at particular states of the tide (Figure 41). These were temporally persistent in the sonar data, often for periods of several tens of seconds. Although these did not appear to markedly influence probability of imaging seals, they (and other small items of debris; e.g. seaweed) were frequently detected and tracked by the SeaTec software (101 tracks). These were included in the dataset for the classification analyses.

Mean distance of confirmed seals from the sonar HiCUP ranged from 15.3 to 59.8 m and peaked between 40 and 45 m (Figure 42). The mean distance of other targets ranged from 16.1 to 58.5 m and peaked between 15 and 20 m. The mean velocity of confirmed seals ranged from 0.6 to 4.7 ms^{-1} and peaked between 2 and 2.5 ms^{-1} . The mean velocity of other targets ranged from 0.3 to 11.3 ms^{-1} and peaked between 1 and 1.5 ms^{-1} .

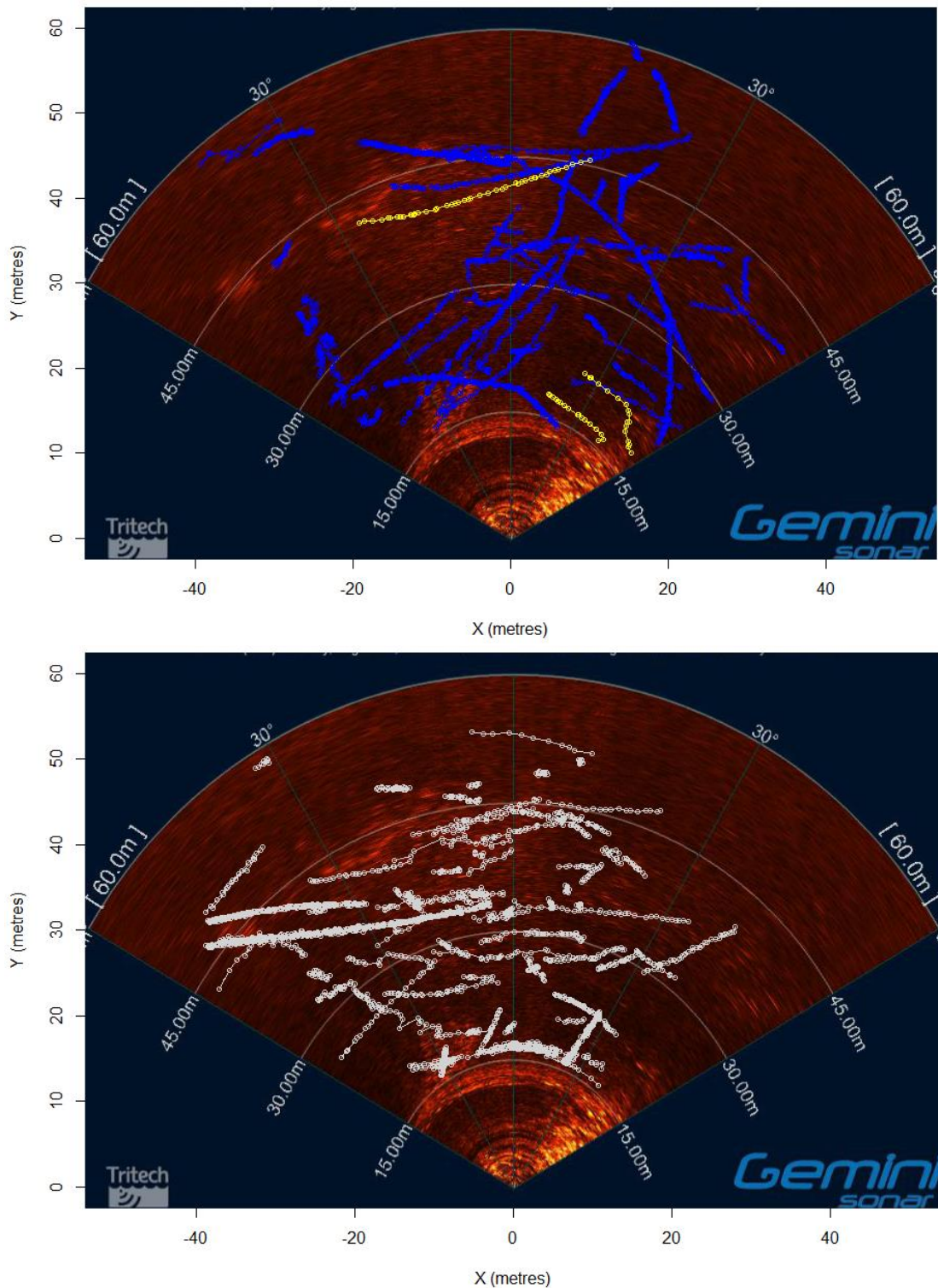

Figure 41: The X-Y tracks of a series of targets detected during the deployment of the multi-beam sonar on the HiCUP in Kyle Rhea. Each panel shows the X-Y locations of targets that were automatically detected and tracked using the SeaTec detection software. The upper panel shows the tracks of targets that were confirmed as seals (blue points) and harbour porpoises (yellow points) through visual observations of animals made from the boat, and the lower panel shows other targets that were likely to be turbulence or items of debris (grey points).

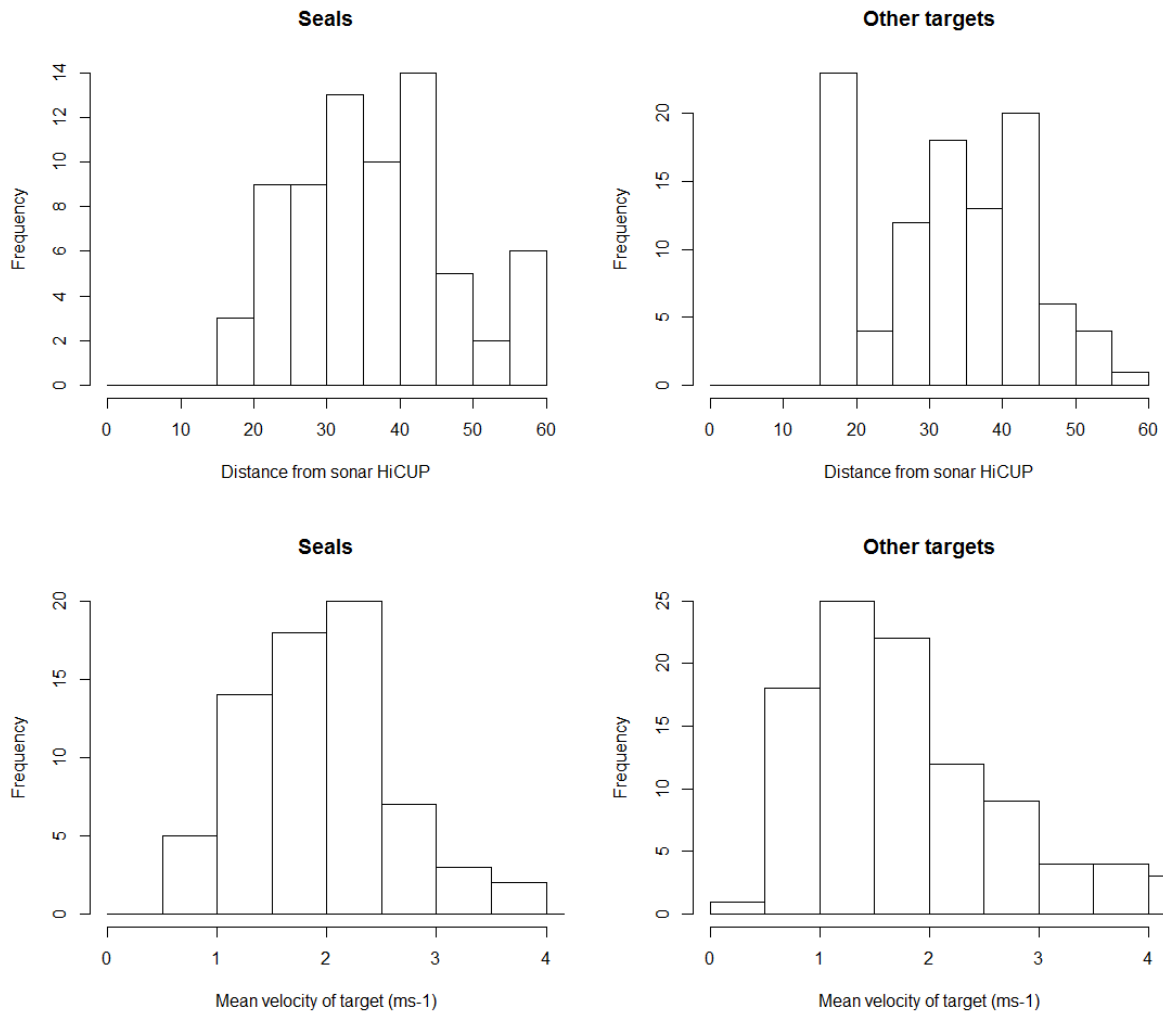

Figure 42: Distributions of the mean distances of confirmed seals and unidentified targets from the sonar HiCUP (upper) and the mean velocities (lower) of confirmed seals and other targets.

To determine whether the tracks of seals produced by the detection and tracking software are at sufficient temporal and spatial granularity to measure the ‘fine scale’ movement behaviour of seals in close proximity to tidal turbines, the time (seconds) and distance (metres) between consecutive detections of seals in the X-Y plane was determined. Results showed that the majority (99.9%) of consecutive detections of seals within a track were less than or equal to one second apart and all were less than two seconds apart. The distance between consecutive detections of seals within a track was generally low; the majority (81%) of consecutive detections were less than 0.5 metres apart and 95% of all consecutive detections were less than 0.9 metres apart (Figure 43). Furthermore, this spatial resolution appeared to be relatively consistent, independent of the distance of the tracked seals from the sonar (Figure 44). This suggests that using the automated detection software to track

seals in tidal currents up to approximately 3 ms^{-1} allows their movement behaviour in the X-Y plane to be measured with sub-metre spatial resolution.

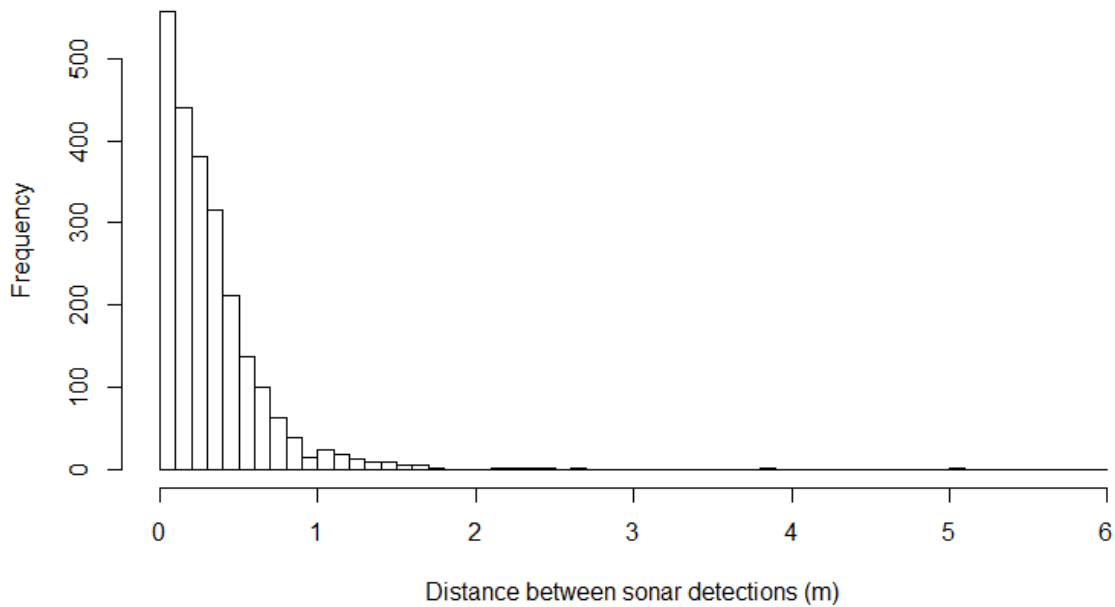

Figure 43: Distribution of the distances (metres) between consecutive sonar detections of seals. The majority (81%) of consecutive detections were less than 0.5 m apart and 95% of all consecutive detections were less than 0.9 m apart.

Perhaps most importantly, this resolution should be considered within the context of detecting collisions using active sonar. This requires information on the 3D location of the seal with sufficient accuracy to confirm that the rotor and seal was in same place at the same time. Although the results in the X-Y plane suggest this would be possible, the errors associated with locating the seal in the vertical plane (mean absolute error = 1.5 m) suggest that although the sonar system should be capable of tracking seals in 3D around the turbine, it will be unlikely to reliably confirm collisions with rotors. However, the combination of the dual sonars with additional sensor technology (video / rotor movement data) is likely to assist in the detection of collisions.

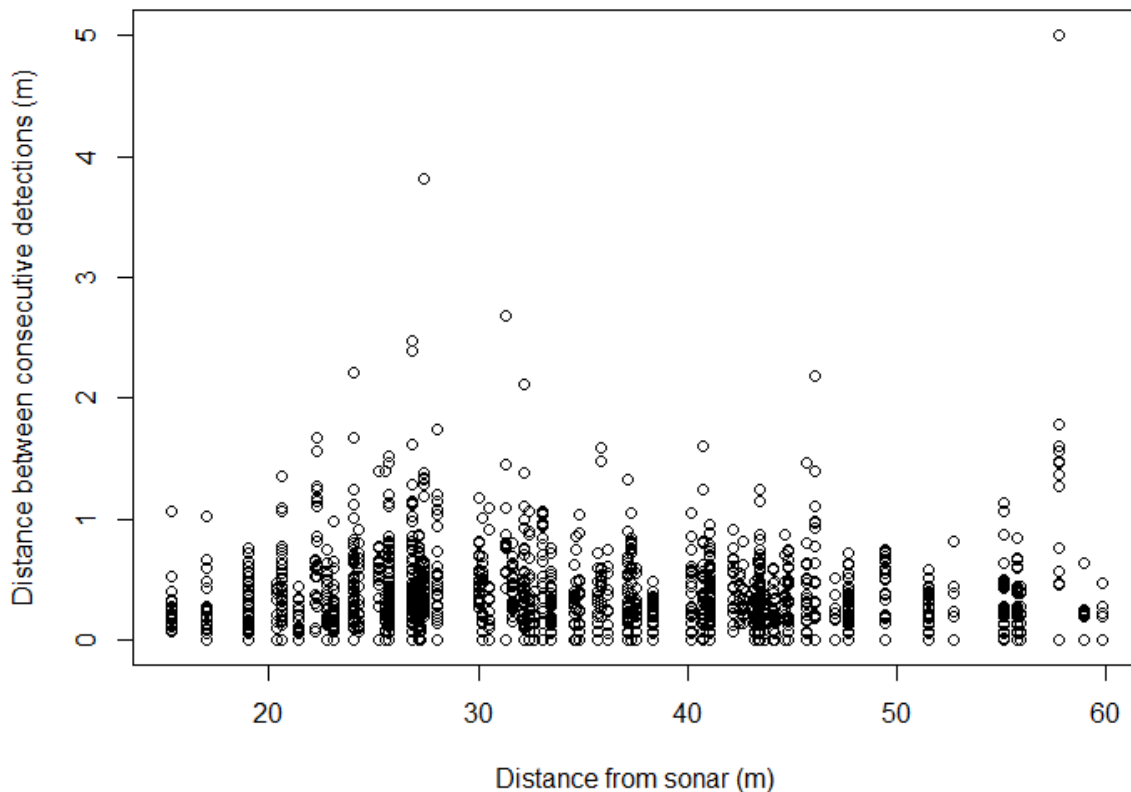

Figure 44: The distances (m) between consecutive sonar detections of seals plotted as a function of distance of the seal from the sonar (m). The majority of consecutive detections were less than 1 m apart independent of range from the sonar.

6.7.2. Sonar HiCUP deployment B – long term functionality

A second deployment of the HiCUP with dual Gemini sonars was made in the Sound of Sleat, together with the two PAM HiCUPs (see deployment description in Section 5.1.3). From a sonar development perspective, the primary aims of this deployment were to:

1. Evaluate the operation of the dual Gemini sonars on a fixed seabed mounted platform for a period of weeks;
2. Investigate the imaging capabilities of the dual configuration of sonars from a seabed mounted perspective (evaluate effects of surface turbulence/wave action on the sonar data);
3. Collect additional data to validate the marine mammal algorithms (sonar data in combination with visual observations of marine mammals);
4. Collect data to validate 3D marine mammal tracking.

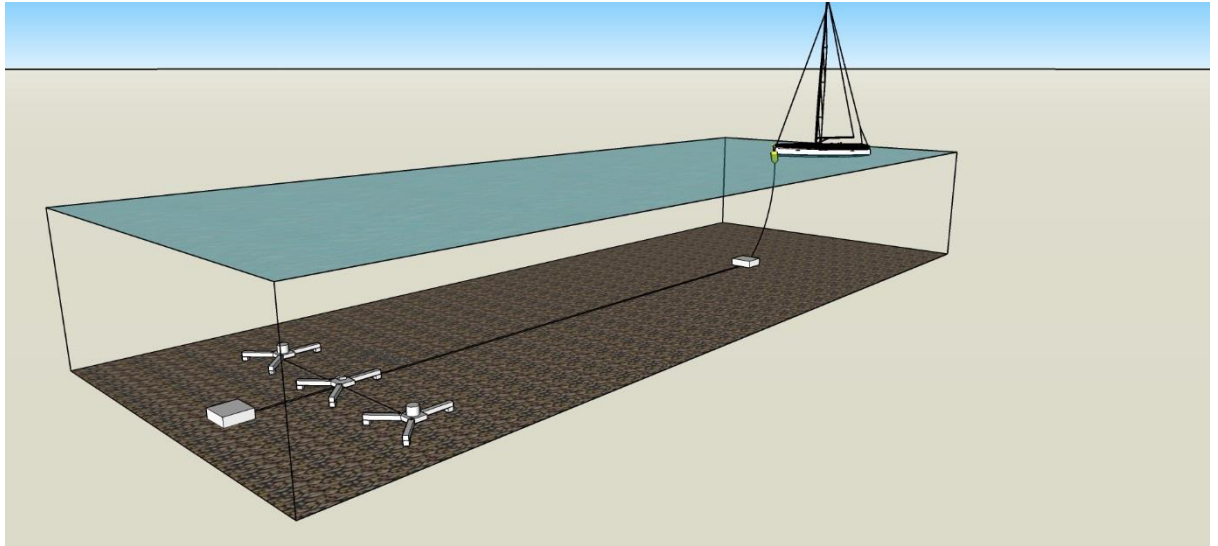

Figure 45: Schematic of the sonar HiCUP mooring deployed in the Sound of Sleat showing seabed mounted sonar and PAM HiCUP, the two secondary anchors, and the research yacht.

Sonar cables were moored along the seabed from the sonar HiCUP to a moored research vessel where the sonar data were monitored in real time and saved for post hoc analyses (Figure 45). The Tritech software SeaTec was used to monitor the sonar data from each of the Gemini sonars. Furthermore, the software PAMGuard (www.PAMGuard.org) was run to ensure that the internal clock on the laptop was synchronised with GPS time. This was required in order to match any tracks of marine mammals recorded using the sonar with those constructed using the PAM system.

The Gemini sonars operated efficiently throughout the longer term deployment in the Sound of Sleat. The sonars were deployed for a period of 20 days between 5 and 25 August 2015, during which time data were collected on a total of 17 days. The sonar systems proved very reliable with 13.5 TB of sonar data being collected near-continuously over the periods when the research vessel was present. Poor weather intermittently required the research vessel to leave the mooring and disconnect the sonar HiCUP cables, resulting in occasional gaps in data collection. Over this period, no observable biological growth was present on the sonar transducers or housings, although, it should be highlighted that growth at other times of the year may be significantly greater.

Due to the error in deployment location, the sonar HiCUP was deployed in a shallower location (~8 m) than anticipated. It was, therefore, not possible to effectively evaluate the effects of surface turbulence/wave action on the sonar data at the water depths anticipated for deployment around tidal turbines. Furthermore,

the shallow depth precluded meaningful validation of the 3D marine mammal tracking using a seal carcass. Nevertheless, the broad principle that provides the basis for 3D tracking was evident in the data with many targets having differential peak intensities associated with them on each sonar. This, together with the results of the vessel based calibrations, suggests that the 3D tracking techniques tested in Section 6.1 should be readily applicable from sonar data collected on a seabed mounted platform around a tidal turbine.

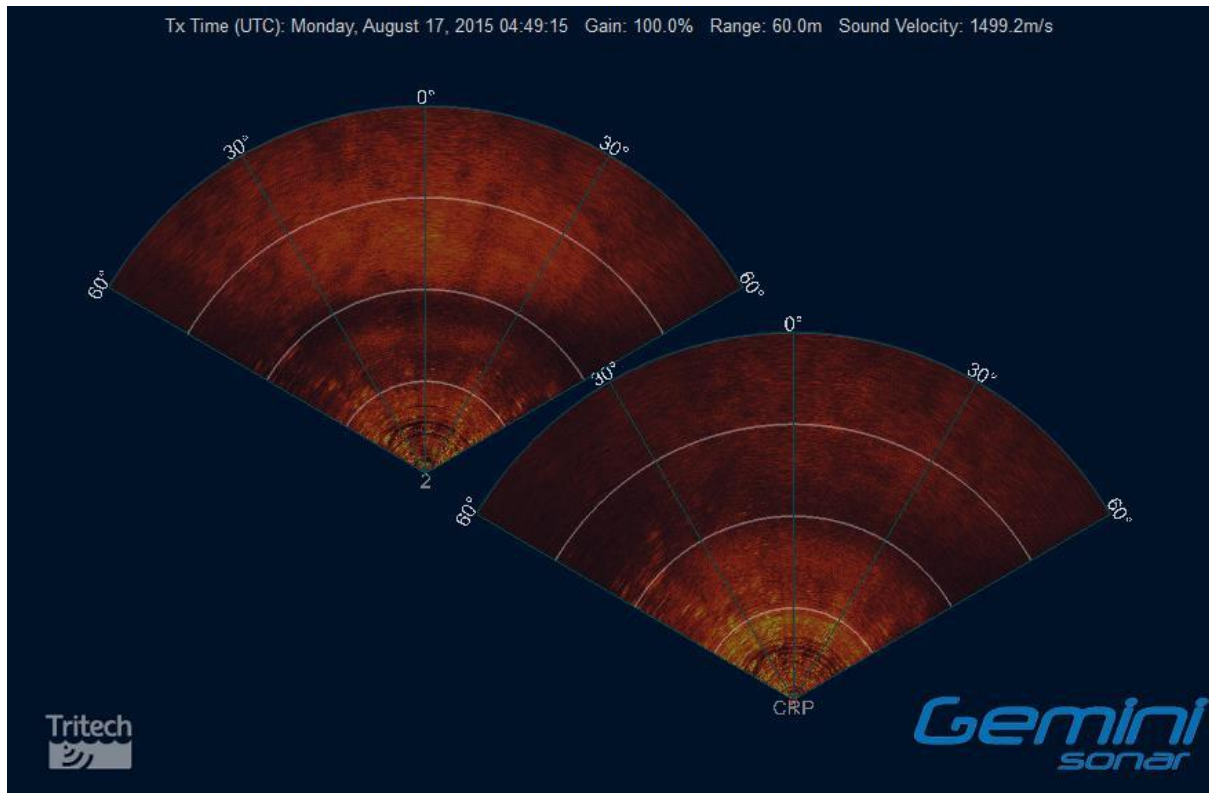

Figure 46: Screenshot of the data from each of the Gemini sonars; the lower right sonar swathe is from sonar that was orientated to be parallel with the seabed and the upper left swathe is from the sonar that was offset vertically upwards by eight degrees.

Observations of marine animals, including marine mammals and seabirds, sighted near the sonar HiCUP clusters were recorded throughout the deployment (Figure 46). Visual observations included harbour porpoises, bottlenose dolphins, grey and harbour seals, and Northern gannets, although, numbers of sightings were generally low and precluded a meaningful validation of the developed marine mammal classification analysis.

Although this deployment period was clearly far shorter than would be envisaged for monitoring around a working tidal turbine, it does highlight that multi-beam sonar can be collected from a seabed mounted platform and monitored in real time via cabling to a remote monitoring station for extended periods.

7. Video system

Section 3.3 presents two solutions for video surveillance: nacelle or foundation mounted video camera. The foundation-mounted video is the preferred option since the nacelle-mounted camera will not have sufficient field of view to cover the entire arc of the blades. Delays in obtaining specific details of the nacelle configuration meant that detailed consideration of alternative video configurations was delayed. The current position is that an underwater video consultant has been asked to design a video system that conforms to the following, initial, specification:

- Operating depth 40 m
- Field of view 190 degrees
- Frame rate Min 5fps
- Sensor Low light, 5 Megapixel
- Anti-fouling Intermittent UV LED illumination of optical port. Longevity > one year
- Data IP addressable – likely bandwidth requirement \leq 16 mbps per camera
- Electrical 24 V, 500 mA (1 A intermittent for LEDs)

This large 190° ‘fish-eye’ field of view will permit the detections of targets in the general vicinity of the blades. The solid-state ultraviolet LED anti-fouling system on the optical port should be more reliable than a mechanical scrubber.

8. Discussion

The work described in this report demonstrates how a combination of Active Sonar, Passive Sonar and Video can be configured to provide data to identify and localise marine mammals in the vicinity of a tidal turbine. All three sensor systems provide high bandwidth data, and while it would in principle be possible to create a stand-alone system (similar to FLOWBEC) to collect these data, such a system would have a limited lifetime and could not provide data over the temporal scales required to study interactions between marine life and a turbine over a period of many months. The systems described here are therefore cabled systems, reliant on integration into the turbine infrastructure in order to receive power and to transmit data to shore.

8.1. Passive Acoustic Monitoring (PAM)

The PAM system proposed is a multiple array of tetrahedral hydrophone clusters (THCs) capable of three dimensional tracking of harbour porpoises and acoustic tags. Each THC consists of a light frame holding the four hydrophones, mounted within a physically strong but acoustically transparent cowling made of high density polyethylene. Field trials demonstrated that the THCs were reliable and capable of detecting harbour porpoise and bottlenose dolphin clicks. Location accuracy was investigated using trials with an artificial porpoise sound and using simulations. Trials also demonstrated that the spherical cluster design had better timing accuracy than the cylindrical design, which is likely to be a result of a combination of the different shape of the cowling as well as in the spacing of the hydrophones – the domed-spherical cluster had a narrower hydrophone spacing meaning that the signals were less distorted by echoes than the more widely spaced hydrophones in the cylindrical cluster.

The range error in acoustic localisations was generally small (<5 m) out to about 50 m, however, depth error appears to be larger and at least several meters at all ranges. However, due to the issues encountered with the HiCUP placement and the fact that the proposal is to use three, rather than two clusters, the results will underestimate localisation accuracy of a system installed on an operational turbine. The simulations for a system consisting of three clusters around a turbine structure indicate that localisation accuracy improves in all dimensions, the error in range being < 3 m; depth < 0.7 m and angle < 0.5 degrees at 25 m from the turbine.

While timing accuracy of the VEMCO tag pulses is not as good as it is for porpoise clicks (+/- 7.5 μ s as opposed to +/-5 μ s), this has little impact on localisation accuracy at short ranges, and similar levels of accuracy are anticipated as for

porpoises close to the turbine blades. Despite the potential for acoustic tags to provide information from a number of tagged seals in the vicinity of the turbine, consideration must be given to the potential for animals to hear the tags. For example, Stansbury *et al.*, (2015), demonstrated that seals could use signals from 69 kHz acoustic tags to locate fish. The frequency of the tags tested here is 83 kHz and, whilst it is at the upper end of the hearing range for seals, it could still be audible and could potentially affect the seals behaviour.

A number of other hardware and software developments have been made. The PAMGuard software has been modified to allow detection of VEMCO acoustic tags. Work has also gone into developing a data acquisition system capable of processing multiple channels of hydrophone data at a high sample rate. This system is currently capable of processing eight channels of data and further work is required to get it to 12 channels (see Section 8.4.1).

8.2. Active Acoustic Monitoring (AAM)

Significant progress has been made in relation to the development of active sonar as a technique for detecting and tracking marine mammals around tidal turbines. Previous deployments with a single multi-beam sonar only allowed the x, y positions of targets to be determined. This project has developed and tested a technique to track marine mammals in 3D in a tidally energetic environment. Two different sonar configurations were tested for this and it was concluded that an overlapping parallel horizontal orientation provided the best results. By measuring ratio of the sonar intensity of a target imaged simultaneously on two sonars arranged in this way, the depth of the animal can be calculated. The error in depth estimated in this way is approximately 1.5 m (although this error may be less when the sonars are mounted on a static platform).

An efficient algorithm for the classification of marine mammals in multi-beam sonar data has been developed which is capable of reducing the high false positive rate reported in previous studies (Hastie, 2012). Cross-validation of the resulting algorithm estimated a cross validation error of 6%. All confirmed seals were correctly classified using the algorithm, while only 8% of non-seal targets were classified as seals. Given the 8% rate of false positives and the number of likely non seal targets in any dataset collected in a tidal environment, relative to the number of real seal targets this still may represent a reasonable number of false positive detections. If this result holds with future datasets, the analytical approach developed will be an effective means of detecting and classifying seals.

The bottom mounted configuration likely to be used in the turbine site deployment has also been successfully tested in a tidally energetic environment and it has been demonstrated that tracking and detection algorithms can still detect marine mammals against a backdrop of additional background noise and surface clutter.

8.3. Video Surveillance

It is expected that video surveillance will provide, during periods of daylight and good visibility, fine scale details of encounters detected by the PAM and AAM systems. However, the uncertainty surrounding the video systems employed by the developer have delayed testing of any video systems in the field. In January 2016 it became evident from the developer that only a foundation mounted system would be feasible. Commissioning of a suitable camera, housing and anti-biofouling system are currently on-going.

8.4. Proposed tidal turbine site deployment – MeyGen

At an early stage in this project, it became apparent that MeyGen's Inner Sound tidal array would be the first commercial array deployment in Scottish waters, therefore, a decision was made to work towards the deployment of the equipment developed as part of this project at that site. The timing of the deployment of turbines at the site is beyond the timeline for the current project so phase two of the SGDS project will cover the actual deployment and commissioning of equipment and the collection and analysis of data.

A number of developments are required to enable progression to this second phase. This section of the report summarises the progress to date towards this objective and outlines the remaining tasks. Consideration is given to hardware and software developments required as well as to processes for data collection, processing and storage.

MeyGen have agreed to provide a cable (power and data) interface to allow connection of an SGDS developed 'instrumentation platform' to one turbine, and discussions are on-going to integrate into a monitoring system that includes other sensors and clarify the alignment of the SGDS objectives (current phase and next phase of SGDS project) with MeyGen consent conditions in terms of data ownership, processed outputs (deliverables to enable consent), contingency in case of monitoring equipment failures, operating durations and equipment ownership.

Phase 1a of the MeyGen Inner Sound deployment consists of three Andritz Hammerfest turbines and a single Atlantis AR1500 turbine. The Atlantis turbine will be instrumented as part of this project, as it was the only turbine with the power and data bandwidth capability for the preferred monitoring equipment. .

8.4.1. PAM

Trials and simulations have shown that the deployment of three THCs will provide accurate tracking around the turbine site. Detection range will ultimately depend on background noise levels in the vicinity of the turbines and the level of any electrical noise from the turbine.

In order to test the performance of the cowlings in a high flow environment, the domed hydrophone cluster was deployed on the FLOWBEC frame for a period of two weeks in October 2015. Data were collected using two SoundTrap recorders, sampling at 576 kHz, one mounted inside the cowling and one outside. Noise was dominated by the EK60 sonar as can clearly be seen in Figure 47. Multiple arrivals of each EK60 ping are visible, separated by 50 ms, which is consistent with multiple surface/bottom echoes in a water depth of around 36 m. At low frequency, during tidal flow, “thumping / flapping” noises could be heard, probably made by loose material on the FLOWBEC frame vibrating in the flow and hitting part of the frame. Examining very short sections of data between EK60 pings indicates spectrum level noise levels within and outside the cowling were broadly similar at different frequencies (Table 13). At the high frequencies of interest, noise increased from 30 to 57 dB re 1 $\mu\text{Pa}/\sqrt{\text{Hz}}$ at times of high flow. It is not possible to tell if the elevated noise is from flow over the FLOWBEC frame or over the cowling. The fact that noise levels were very similar for the internal and the external SoundTraps perhaps indicates that the dominant source of noise is independent of those parts of the structure. The consequences of the higher noise level for monitoring would not in themselves be too severe. For a 57 dB re 1 $\mu\text{Pa}/\sqrt{\text{Hz}}$ noise level over the entire 70-150 kHz detection band, the broad band noise level would be around 107 dB re 1 μPa . This would be expected to give a detection range of harbour porpoises in excess of 200 m.

Table 13

Spectrum level noise levels measured between EK60 pulses at low and high flow for a cowling installed on the FLOWBEC platform in October 2015. Units are dB re 1 $\mu\text{Pa}/\sqrt{\text{Hz}}$.

	Low Flow (2015-10-10 04:10 UTC)		High Flow (2015-10-10 07:10 UTC)	
	10 kHz	130 kHz	10 kHz	130 kHz
Inside Cowling	42	30	72	57
Outside Cowling	38	30	70	57

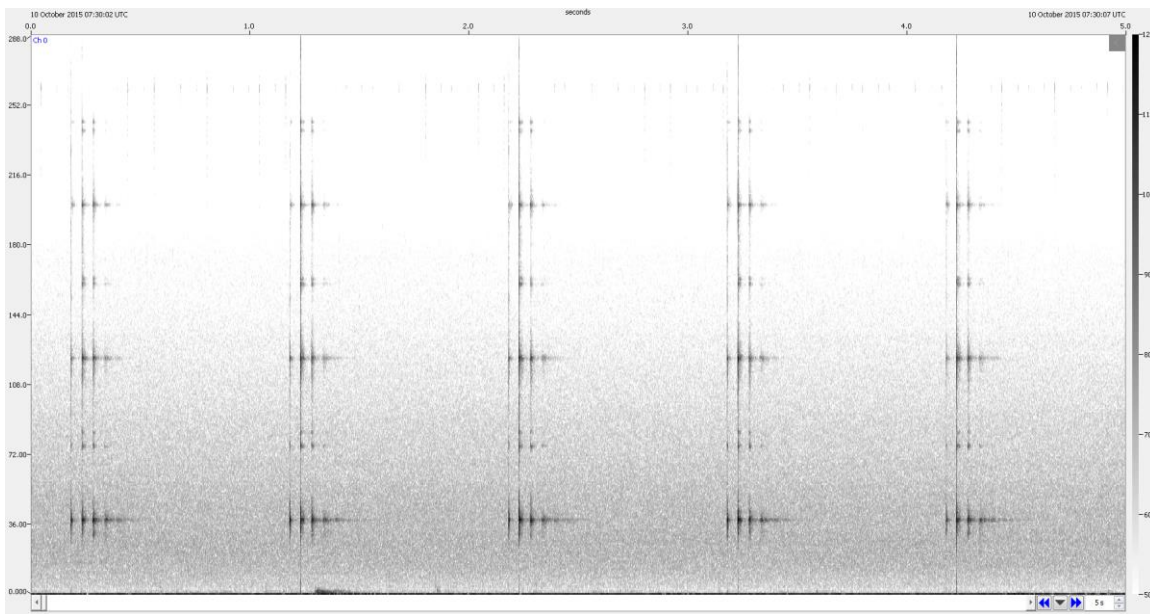

Figure 47: Spectrogram of five seconds of data collected using a SoundTrap recorder mounted on the FLOWBEC frame. Y axis scale in in kHz.

It is also expected that in most circumstances VEMCO tags will be detected out to 100 to 200 m range. Detection ranges of dolphin clicks should be several times greater.

There is currently one domed THC, with a requirement for another two to be built. Although the components are available for the clusters themselves, similar dome shaped polyethylene cowlings will need to be sourced or made as these are not mass produced. These THC units have not been tested in areas of particularly high flow (Sound of Sleet deployment was restricted to relatively low currents). However, the present design, with a small amount of modification, should be robust enough to withstand currents at the MeyGen site in the Pentland Firth.

8.4.1.1. Installation

A number of actions are required prior to installing the PAM system on a turbine. Firstly, the design and manufacturing of the protective cowlings around the hydrophone clusters needs to be finalised in order to provide a cost effective, but robust solution, which can be delivered over a relatively short time frame.

Discussions with MeyGen engineers are taking place to finalise mounting of the PAM system on the turbine and housing of the PAM acquisition system in a suitable dry space.

MeyGen engineers are also considering the type of cabling and connectors to be used between the individual clusters and the central junction box. This may depend on the logistics of installing and mounting the equipment and should wherever possible follow the same standards being used for other turbine cabling. It has been agreed that it will not be possible to access the clusters after deployment for any maintenance or replacement, therefore, it is likely that the cables will be hard wired into the THCs with the cables routed in protective conduits between each THC and the central junction box.

8.4.1.2 Shore Side Processing

As it has been established that the same detectors can be used for both cetacean sounds and the VEMCO tags, shore side processing of the PAM data can take place on a single high specification desktop PC. Data rate from the turbine will be high, so a minimum of a 100Mbps Network connection will be required.

The PAM PC will run the PAMGuard software configured to detect both cetacean clicks and whistles and the VEMCO tags. Clicks will be automatically classified as porpoise, dolphin, VEMCO or noise based on frequency content and duration. The system will also measure ambient noise levels and a separate watchdog program will be used to ensure long term system reliability. The system will have the capability of recording raw audio data, but it should be noted that raw data volumes are extremely high at around a TB per day. Standard practice will, therefore, be to only record short clips of sound around detections, with the possibility of making longer recordings, particularly for diagnosing system performance during commissioning stages. These data will be stored in binary data files which are generally small enough to be transferred between sites via the Internet. These data can be easily summarised on a regular basis in terms of numbers, dates and times of detections for reporting to the regulator or for further analysis. Tracking data will need further post hoc analysis to describe and interpret behaviour (see Section 8.6).

It will be possible to configure a live audio stream from up to two of the 12 hydrophones. It will also be possible to configure an audible alarm in the event of detection of different click types.

Video (probably at a rate of five fps) will also be live streamed to shore side for storage and subsequent inspection when PAM or AAM detect a potential encounter.

8.4.1.3. Data Volume and Management Strategy

Raw data from all 12 hydrophones sampling at 500kS/s will have a total volume of a TB per day. Generally, except during commissioning stages of the monitoring program, storing all of the raw data will not be considered. Binary data files from the detectors and noise monitors may amount to approximately 400 MBs per day (a reduction of 2500:1 compared with the raw data), although this is heavily dependent on how detectors are configured and noise conditions around the turbine. In addition, at least some diagnostic recording will be required, although how much can only be determined in the light of how noisy (i.e. how difficult to interpret) data from the detectors are. Following the initial commissioning period, the system may be set to record raw audio data when animals have been automatically detected. The PAMGuard software also writes operational log files (including any error messages/crash reports) to log files on the system hard drive. Binary data will initially be written to an internal hard drive and backed up daily onto external storage. Assuming sufficient network bandwidth is available, binary and PAMGuard log files data will be uploaded to SMRU on a weekly basis. Larger volumes of data (i.e. recordings) will need to be recovered on hard drives as required. For quality control and preliminary data checking, binary files and system log files will be checked on a weekly basis. More detailed detection confirmation and track analysis will take place on a monthly basis. The proposed data management schedule for PAM data is summarized in Table 14.

Table 14

Proposed data management scheduling for PAM data.

Activity	Data Volume	Location	Timing
Real time detection results saved to hard drive	Approx. 400 MB / day	Internal hard drive	Real Time
PAMGuard system log files	MB's / day	Internal hard drive	Real Time
Backup of detection results and log files	Approx. 400 MB / day	Local external USB drives	Daily
Continuous Recording	1 TB / day	External 4 TB USB hard drives	Real Time (Commissioning only)
Detection triggered recordings	To be determined	External 4 TB USB hard drives	To be determined
Upload of detection and log files via remote access	Approx. 400 MB / day	Remote data recovery to disk drives at SMRU	Weekly
Recovery of recordings	Many TBs	Recovery of hard drives	As required.
Data quality control		SMRU	Weekly
Detection confirmation and tracking		SMRU	Monthly

8.4.1.4 Alarms and SCADA Interface

Various alarms can be configured within the PAMGuard software which can show both visual and audible alarms on the PAM PC and also send RS232 NMEA like information sentences to a remote computer. For example, these could be sent to the central control system and integrated into other system data streams in order to alert the system operator at times when a dedicated PAM operator is not present. How these are configured will require discussion with other engineers developing the controls systems for the turbine and dependent on the monitoring strategy required by MeyGen during operation.

8.4.2. Acoustic Tags

On the basis of pinger tests it is suggested that the deployment of the 83 kHz VEMCO tags in combination with GPS UHF tags, would enable tagged harbour seals to be identified and tracked in the vicinity of the turbine. This would enable tracking to an accuracy of 1-2 m around the turbine blades which would provide a relatively good spatial resolution in three 3D which would be sufficient to measure any avoidance reactions at the scale of metres around the turbine. However, it is unlikely that this would be sufficient to determine whether or not animals actually

collide with turbine blades. This information could be obtained during daylight and good visibility from the video surveillance. An analysis of the required sample size needs to be carried out to inform the tagging study design; it will be important to use an estimate of how often a tagged animal is likely to come within detection range of the system based on prior knowledge of seal movements in the area.

8.4.3. AAM

The results of the series of tests carried out in this project using the multi-beam sonars were highly encouraging with respect to designing a sensor system to track marine mammals around tidal turbines. Specifically, the results of the detection and tracking tests of seals within a tidally energetic location (tidal currents up to approximately 3 ms^{-1}) showed that seals could be effectively detected and tracked from a seabed mounted sonar system. Results of measurements of the spatial granularity of seal tracks produced by the detection and tracking software showed that movement behaviour in the X-Y plane would have sub-metre spatial resolution; the majority (81%) of consecutive detections were less than 0.5 m apart and 95% of all consecutive detections were less than 0.9 m apart. Furthermore, the development of the dual sonars appears to be an effective means of tracking seals in 3D in tidally energetic locations. Specifically, the results of the calibrations using the dual sonars showed that the depth of a seal could be accurately predicted by either mounting the sonars in perpendicular orientations (errors ranged from -3.0 to +4.9 m with a mean absolute error of 1.6 m) or by mounting them in an offset parallel orientation (errors ranged from -2.6 to +4.3 m with a mean absolute error of 1.5 m). Together, these results show that seals can be tracked around tidal turbines with good spatial resolution (sub-metre) in the X-Y plane and with an accuracy of around 1-2 m in the depth plane. So, any evasion responses largely in the horizontal plane will be detected with a good degree of accuracy although vertical responses will be associated with more error. This has obvious implications for the assessment of whether a collision has occurred; specifically, the error in depth estimation makes it unlikely that a collision can be reliably confirmed using the AAM system.

Based on previous development work (Hastie, 2012) and the results of this study, it is proposed that the most effective location for the seabed mounted sonars is 30 m to the side of the turbine axis and orientated so that the turbine is approximately mid frame (Figure 49 and Figure 50). This is likely to provide the best coverage of the turbine and would allow targets to be tracked in 3D both upstream and downstream of the turbine. It is proposed that a custom built pan and tilt mechanism is used to fine control the angles once the platform is deployed. Such a system is currently being specified.

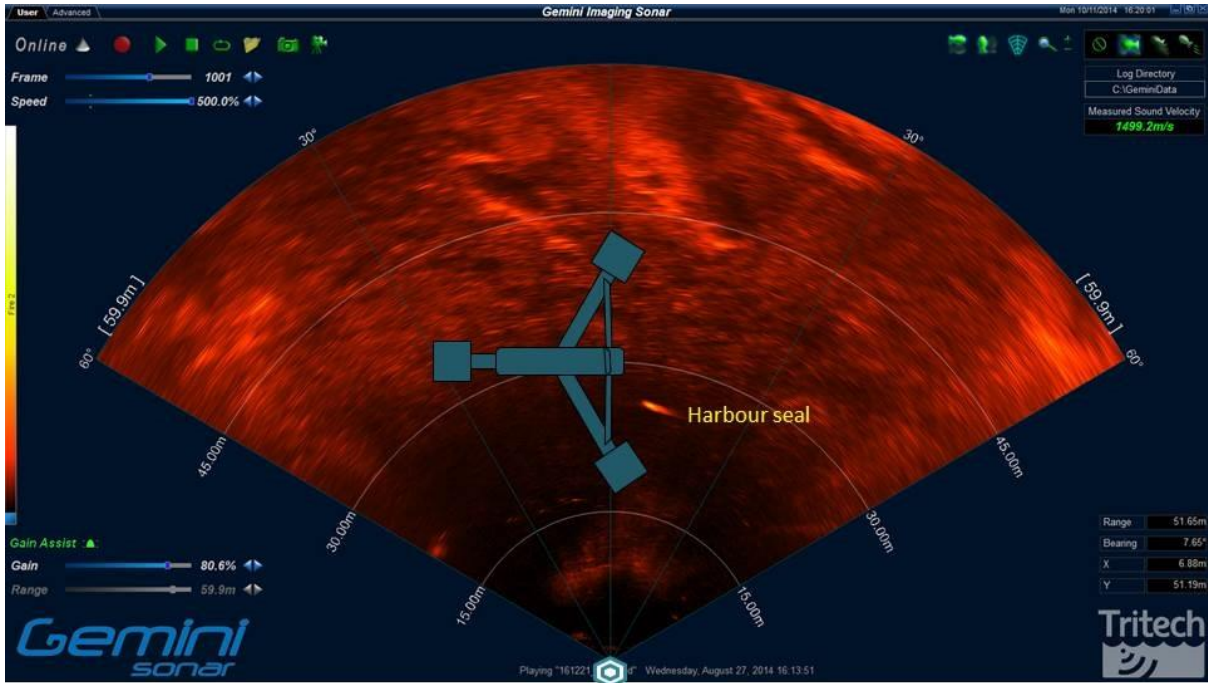

Figure 49: A schematic of the horizontal sonar swathe coverage of a tidal turbine when the sonar is located 30 metres to the side of the turbine. The figure shows an approximation of a tidal turbine with 18 metres diameter rotors overlaid on a sonar image of a harbour seal in a tidally energetic location (Kyle Rhea).

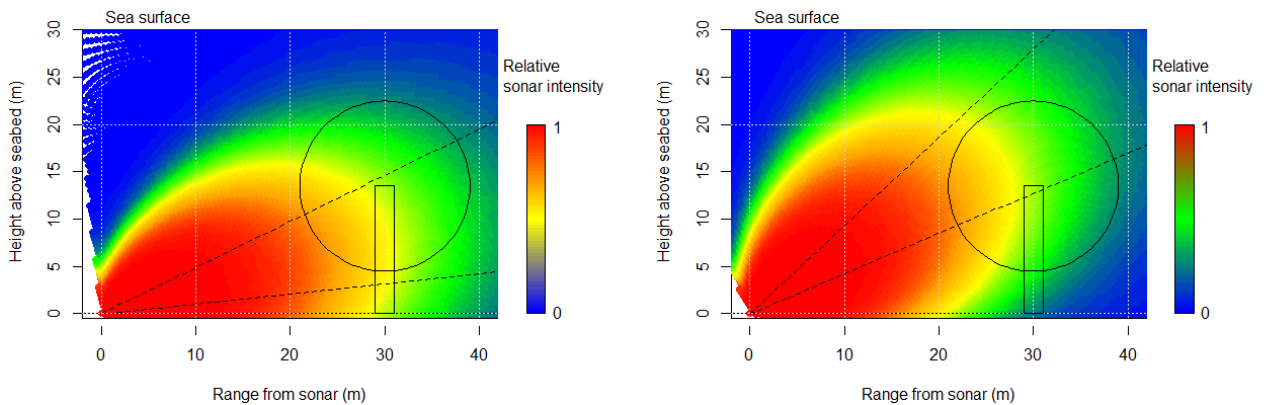

Figure 50: The predicted sonar intensities of a seals in the vertical plane of dual sonars mounted 30 metres away from a tidal turbine and offset by an angle of 17 degrees; the left panel shows the lower sonar and right panel shows the upper sonar. The circle in each figure represents the approximate rotor sweep of an 18 metre diameter turbine with the rotor centred 13 metres above the seabed, the dashed lines represent the 20 degree vertical sonar swathe reported as the -3dB coverage of the sonar by the manufacturer, and the coloured areas represent the modelled intensities of a seal based on the measurements made with a grey seal carcass in Section 6.

Although good progress has been made to providing a sonar solution for tracking seals in 3D around operating tidal turbines, there are a number of development tasks that need completing prior to deployment at the MeyGen site in the Pentland Firth. Firstly, from a software perspective, the new classification algorithms and 3D

tracking will need to be integrated into the existing SeaTec software to reduce post hoc analyses. This is currently on-going and should be completed prior to deployment. Secondly, the image of the rotating turbine and any associated turbulence may result in false detections - this may need to be taken into account in the automatic detection software and any areas of significant noise 'masked' out.

From a hardware perspective, the platform that will mount the dual sonars will need to be designed and fully approved by the turbine manufacturer prior to deployment at the desired tidal turbine location. Although the HiCUP platform has been tested in Kyle Rhea in flows of up to 4 ms^{-1} , it has not been tested at the Inner Sound site. MeyGen are currently reviewing the design of the platform to assess its suitability for the Inner Sound site. It is also recommended that a protective housing is provided for the sonars to protect from debris being carried in the current. Based on the trials of polyethylene described in Section 6.5, there will need to be a clear opening for the sonar heads.

Similarly, mounting locations of the sonar topside processing and power management housings will need to be considered. Finally, if additional active acoustic sensors (e.g. ADCPs) are planned for deployment around the operating turbine, crosstalk between the systems potentially compromising the data is possible. From this perspective, synchronising the pings of the different systems should be considered. Discussion is underway between Benjamin Williamson (under a NERC Knowledge Transfer Partnership between MeyGen and the University of Aberdeen) and Trittech software engineers to develop the most effective solution.

8.4.3.1. Shore Side Data Processing, Analysis and Storage

Sonar data will be processed in real time on-shore using a dedicated PC and both sonar image data (*.ecd files) and associated detection and classification files (*.txt files). These files will store summary information on detection timings, target tracks including X-Y locations, X-Y velocity, a measure of the probability that the target is a marine mammal, and summary information required to calculate depth) will be stored on two external 4TB HDs simultaneously (two backup datasets). The PC should have the following specifications: 16 GB RAM, 3.5 GHz (Quad-Core) processor, 3D hardware accelerated graphics card, 1600x1200 (32bit colour) display. There should have a means of remotely accessing the PC to allow monitoring offsite.

It is proposed that sonar image data is collected 24/7 together with the detection and track files for at least the first month of deployment. This should allow the efficiency of the system to be assessed prior to switching to a more data efficient means of

monitoring. Raw sonar image data (*.ecd) from the dual sonars will be simultaneously recorded to two external hard disks. This will amount to approximately 214 GB per day; one month of data will, therefore, require approximately 12.8 TB (6.4 TB on each of two backup hard disks). Once the system has been tested over the first month of operation, it is proposed that the data collection is switched to a more data efficient means of monitoring (Table 15). Specifically, the automated marine mammal detectors will be run 24/7 to produce summary detection files (*.txt). These will be saved on the two external disk drives. The raw image files associated with each automated marine mammal detection will also be saved automatically on the two disk drives for post hoc validation purposes. It is proposed that the summary detection files are remotely downloaded on a frequent basis (daily if practical) for storage in a database on a backup hard disk at SMRU. This would provide a means of efficiently post processing the detection and classification data to produce 3D tracks of marine mammals in the vicinity of the turbine. Remote monitoring of the data volumes on the external disk drives on the shore side PC will also provide a means of identifying when disk drives will need replacing. This approach would also provide an efficient means of reporting marine mammal detection rates and movements (pre-validation) at a desired reporting schedule or a way to quickly interrogate track data for periods of interest, e.g. if other monitoring sensors indicate a collision or close range interaction with the turbine.

Depending on MeyGen's requirements during real time operation – it is possible to configure the SeaTec software to provide alerts if potential marine mammal targets are detected within a specified range of the turbine.

8.4.4. Video

A video engineer has been commissioned to finalise a design where wide-angle video cameras will be attached to each of two of the foundation legs. Power and data will be provided by a cable running parallel to (but far enough away to avoid cross talk with) the THC pod cabling. These cables will terminate in the foundation dry space provided by MeyGen.

The bandwidth requirements for twin video cameras is $4 \text{ MB s}^{-1} = \text{c. } 350 \text{ GB per day}$. With Gigabit Ethernet, sufficient bandwidth will be available for both this, the PAM and the AAM systems, although stability testing will be required prior to installation.

Table 15

Proposed data management scheduling for the active sonar system.

Activity	Location	Timing
Saving of detection and classification files (*.txt) from Gemini	Dual 4TB disk drives connected to shore side PC	Real time
Saving of raw sonar data (*.ecd) associated with detections	Dual 4TB disk drives connected to shore side PC	Real time
Download detection and classification files (*.txt) via remote access*	Disk drive located in PC at SMRU	Daily
Manually replace and archive dual 4TB disk drives connected to shore side PC	Shore side PC	Monthly**
Post process detection and classification files to create 3D tracks	PC at SMRU	Monthly

* Dependent on internet bandwidth.

** This will be dependent upon data volumes and may be more or less frequent

It is proposed that video data are collected 24/7 for at least the first month of deployment. Thereafter, it is proposed to review the quality of the recordings and to limit recording to daylight hours. It is also proposed that a single shore-side PC is dedicated to acquiring, displaying and storing video data. Data files should be appended every 24 hours so that a PC failure will result in a maximum of 24 hours of data loss. Facility should be available for regular remote downloading to a dedicated server. Also, facility should also be made available for real-time remote monitoring of images when requested.

8.5. Generic Application Principles

While the focus of efforts has been to develop systems which can be integrated into a specific turbine (AR1500), most of the basic design principles are applicable to the use of these sensors in other situations. Fundamental to all systems are power and communications. Both the AAM and the PAM systems require several watts of power. Similarly, both the PAM and the AAM systems produce high volumes of data with a 12 channel PAM system producing around a TB of raw data per day. While data volumes could be reduced through data compression, multiple high capacity hard drives would be required to run the system autonomously for more than a week or so.

PAM tracking accuracy is best close to the PAM array, so the preferred option will always be to mount the PAM hydrophones on the turbine support structure. As well as being close to the turbine blades, rigid mounting has the advantage of accurate

hydrophone placement which is essential for accurate localisation of sound sources. However, individual turbine designs might not allow hydrophone clusters to be attached at the required spacing for accurate tracking at the desired ranges. If hydrophones were mounted off the device on separate platforms, then a system for accurate location of the hydrophone systems would have to be developed.

To achieve full coverage of the turbine blades, a cabled AAM system needs to be sited some distance away from the structure, with the exact distance depending on the geometry of the turbine and the size of the rotor swept area. The preference is for the sonars to be to the side of the structure (looking across the current).

For video monitoring consideration needs to be given to the local visibility at the site and to the potential for bio-fouling.

The potential for interference from other monitoring systems must be considered. In particular, other active acoustic devices, for example ADCPs and other acoustic monitoring equipment (e.g. echo sounders for monitoring fish) emit high frequency signals which may interfere with the active and passive detectors, but could also potentially affect the behaviour of animals around a device. ADCPs in particular are likely to be a necessary part of tidal turbine deployments and, therefore, will always be an issue that needs to be considered. The potential for inter sensor interference can be addressed by synchronisation of devices. However, the potential for avoidance may pose a more serious problem when trying to measure and interpret the behaviour of marine mammals around tidal energy devices. It is important that any monitoring/measurement systems that are unique to the demonstration, instrumented turbine installation, have minimal biological effect.

8.6. Data Analysis Requirements in Relation to Final Deployment

Existing information on harbour seal abundance in Gills Bay (where the MeyGen turbine will be installed) suggests that the encounter rate with the turbine will be low (Thompson *et al.*, 2015). Little information exists about the likely encounter rate with harbour porpoises. As a result, it is likely that a monitoring programme would have to last for at least a year in order to gather sufficient data to estimate both close encounter rates and evasion behaviour, which are the data needed to parameterise collision risk models.

The proposed sensor deployment will produce three data sets: PAM, AAM and video surveillance. It is likely that data will be generally sparse due to the expected low encounter rate of seals and porpoises. It is also likely that data about individual

encounters will be fragmented. For PAM this may be due to fragmented click/ping sequences due to changes in posture of a porpoise or acoustically tagged seal, and thus the received acoustic signal level. There will still be a degree of error in the locational information for each detection. For AAM there will still remain an element of uncertainty about the exact position and classification of the perceived target. For video surveillance it is also likely that there will remain an element of uncertainty about the exact position of the target in relation to the blades. It would be useful, therefore, to consider the construction of a Bayesian movement model that could incorporate these three disparate data sets (with uncertainty) to predict a best estimate (with uncertainty) of the 3D trajectory of animals in the vicinity of a turbine blade. This will provide a better ability to make inferences about the behaviour of animals around turbines, and to determine whether collisions are taking place.

Similarly, there will be a level of uncertainty as to how well video surveillance (during the windows in which it can operate) detects the outcome of an encounter - whether there was successful evasion or a turbine impact. An uninterrupted vocal sequence of clicks continuing after a close encounter with the rotor area would suggest that a porpoise has evaded impact. Similarly, if the track data suggests an interrupted movement path this would suggest a lack of impact. Again, there is a need to combine data sets (and perhaps others such as strain gauge information on the turbines) in a Bayesian model to estimate the most likely outcome of a close encounter.

9. Literature Cited

Band, B., Thompson, D., Sparling, C., Onoufriou, J., San Martin, E. and West, N. in review. Refining estimates of collision risk for harbour seals and tidal turbines. SMRU Consulting and ABPmer report to Marine Scotland. Report number SMRUC-ANP-2016-006 March 2016.

Chawla, N.V., Bowyer, K.W., Hall, L.O. and Kegelmeyer, W.P. 2002. SMOTE: synthetic minority over-sampling technique. *Journal of Artificial Intelligence Research*, 16(1): 321-357. (implemented in R package 'unbalanced').

Cryer J.D. and Chan K.S. 2008 *Time Series Analysis With Applications in R*. New York: Springer. ISBN 9780387759586.

Faber Maunsell & Metoc, 2007. *Scottish Marine Renewables SEA Environmental Report*. http://www.seaenergyscotland.net/SEA_Public_Environmental_Report.htm.

Gillespie, D.M., Mellinger, D., Gordon, J.C.D., McLaren, D., Redmond, P., McHugh, R., Trinder, P., Deng, X. and Thode, A. 2008. PAMGuard: Semi-automated, open source software for real-time acoustic detection and localisation of cetaceans. *The Journal of the Acoustical Society of America*, 30(5): 54-62.

Hastie, G.D. 2012. Tracking marine mammals around marine renewable energy devices using active sonar. SMRU Ltd report URN:12D/328 to the Department of Energy and Climate Change. September 2012 (unpublished).

Hastie, G.D., Russell, D.J.F., Benjamins, S., Moss, S., Wilson, B. and Thompson, D. in review. Dynamic habitat corridors for marine predators; intensive use of a coastal channel by harbour seals is modulated by tidal currents. *Behavioural Ecology and Sociobiology*.

Hastie T.J., Tibshirani R.J. and Friedman J. 2009. *The Elements of Statistical Learning: Data Mining, Inference and Prediction*. 2nd edition. New York: Springer. ISBN 9780387848587.

Johnson, M., Partan, J. and Hurst, T. 2013. Low complexity lossless compression of underwater sound recordings. *Journal of the Acoustical Society of America*, 133: 1387–1398.

Macaulay, J., Malinka C., Coram, A., Gordon J. and Northridge, S. 2015. The density and behaviour of marine mammals in tidal rapids. Sea Mammal Research Unit, University of St Andrews, Report to Scottish Government, no. MR 7.1.2., St Andrews, 53pp.

McConnell, B., Gillespie, D., Hastie, G., Johnson, M. and Macaulay, J. 2013. MR3 Methods for Tracking Fine Scale Movements of Marine Mammals around Marine Tidal Devices. Edinburgh: Scottish Government.

ORJIP, 2016. The Forward look; an Ocean Energy Environmental Research Strategy for the UK. Report to The Crown Estate, Marine Scotland and Welsh Government/ORJIP Ocean Energy, February 2016.
http://www.orjip.org.uk/sites/default/files/ORJIP_Ocean_Energy_Forward_Look_2.pdf.

R Core Team. 2012 R: A language and environment for statistical computing. In. R Foundation for Statistical Computing. URL <http://www.R-project.org/>, Vienna, Austria

Scottish Government. 2011. 2020 routemap for renewable energy in Scotland. Scottish Government <http://www.gov.scot/Publications/2011/08/04110353/0> 124pp.

Scottish Government. 2012. 2020 routemap for renewable energy in Scotland. Scottish Government <http://www.gov.scot/Resource/0040/00406958.pdf> 49pp.

Scottish Government, 2013. Draft Sectoral Marine Plans for Offshore Renewable Energy in Scottish Waters <http://www.gov.scot/Publications/2013/07/8702>

Sousa-Lima, R.S., Norris, T.F., Oswald, J.N. and Fernandes, D.P. 2013. A review and inventory of fixed autonomous recorders for passive acoustic monitoring of marine mammals. *Aquatic Mammals*, 39, 23–53.

Sparling, C.E., Coram, A.J., McConnell, B.J., Thompson, D., Hawkins, K.R. and Northridge, S. 2013. Wave & Tidal Consenting Position Paper Series: Marine Mammal Impacts. Natural Environment Research Council.

SRSL, 2012. Meygen tidal-stream turbine array environmental impact assessment: modelling encounter rate between turbines and marine mammals. Report to MeyGen, reference number 00599 (Commercially confidential).

Stansbury, A.L., Götz, T., Deecke, V.B. and Janik, V.M. 2015. Grey seals use anthropogenic signals from acoustic tags to locate fish: evidence from a simulated foraging task. *Proceedings of the Royal Society B*, 282: 20141595.

Szymanski, M.D., Supin A.Y., Bain D.E. and Henry K.R. 1998. Killer whale (*Orcinus orca*) auditory evoked potentials to rhythmic clicks. *Marine Mammal Science*, 14:676-691

Thompson, D., Onoufriou, J., Brownlow, A. and Morris, C. 2015. Data based estimates of collision risk: an example based on harbour seal tracking data around a proposed tidal turbine array in the Pentland Firth. Sea Mammal Research Unit, University of St Andrews. Report to Scottish Government.

Williamson, B.J., Blondel, P., Armstrong, E., Bell, P.S., Hall, C., Waggitt, J.J. and Scott, B.E. 2015. A Self-Contained Subsea Platform for Acoustic Monitoring of the Environment Around Marine Renewable Energy Devices - Field Deployments at Wave and Tidal Energy Sites in Orkney, Scotland. *IEEE Journal of Oceanic Engineering*, DOI: 10.1109/JOE.2015.2410851.

Wilson, B., Batty, R. S., Daunt, F. and Carter, C. 2007. Collision risks between marine renewable energy devices and mammals, fish and diving birds. Report to the Scottish Government, Marine Renewables Strategic Environmental Assessment.

Wilson B., Benjamins S. and Elliott, J. 2013. Using drifting passive echolocation loggers to study harbour porpoises in tidal-stream habitats. *Endangered Species Research*, 22:125-143

Wood S.N. 2006. *Generalized Additive Models: An Introduction with R*. Boca Raton: Chapman and Hall/CRC Press. ISBN 9781584884743.

10. Acknowledgements

The team would like to thank the following for assistance during field trials: Thomas Gordon, Alex Coram, Arthur Lee, Pauline Jepp, Andy Law, Susie Calderan, Russell Leaper, Andy Coggan and the crew of the Toohey II, Benjamin Williamson and Shaun Fraser.

Thanks also to the Project Steering Group and the team at MeyGen and University of Aberdeen: Ed Rollings, Fraser Johnson, Dave Rigg, Lorna Slater, Benjamin Williamson and Beth Scott.

The equipment was deployed in accordance with Licence Number 05624/15/0, we would like to thank MSLOT for helpful and efficient processing of the licence application despite the short notice given.

This work was also supported by National Capability funding from the Natural Environment Research Council to the Sea Mammal Research Unit (grant no. SMRU1001).

11.0 Glossary

AAM	Active Acoustic Monitoring
ADCP	Acoustic Doppler Current Profiler
AR1500	Atlantis 1.5 MW turbine
DAQ	Data Acquisition
Db	Decibel (unit of sound)
DECC	Department of Energy and Climate Change
EK60	Simrad Echosounder
FLOWBEC	Flow and Benthic Ecology 4D
GB	Gigabyte
GPS	Global Positioning System
GSM	Global System for Mobile Communications
HiCUP	High Current Underwater Platform
HRA	Habitats Regulations Assessment
kHz	Kilohertz
LAN	Local Area Network
LED	Light emitting diode
MB	Megabyte
Mbps	Megabits per second
MCMC	Markov Chain Monte Carlo
NERC	Natural Environment Research Council
NI	National Instruments
NMEA	National Marine Electronics Association
ORJIP	Offshore Renewables Joint Industry Programme
PAM	Passive Acoustic Monitoring
PAMGuard	Software used for collecting and processing PAM data
ROV	Remotely operated vehicle
RS232	Communications protocol
SDM	Survey Deploy and Monitor
SEA	Strategic Environmental Assessment
SGDS	Scottish Government Demonstration Strategy
SMRU	Sea Mammal Research Unit

SVM	Support Vector Machine
TB	Terabyte
TEL	Tidal Energy Ltd
TOAD	Time of arrival delay
THC	Tetrahedral Hydrophone Clusters
UHF	Ultra High Frequency
UV	Ultraviolet
VHF	Very High Frequency
VEMCO	Brand name for animal borne acoustic tracking tags

12. Appendix A

Development of New PAM Timing Algorithms

This appendix describes work undertaken to improve the accuracy of time of arrival differences for VEMCO tag signals, an essential step in localisation using a PAM array.

The standard method of estimating the time delay between two signals is to find the peak in the cross correlation function of those signals as shown in Figure 51. Even for porpoise clicks which are relatively short, the repetitive nature of the click's waveform can result in a multi-peaked cross correlation function making it difficult to select the correct peak. This problem becomes significantly worse in the presence of noise and reverberation (echoes), all of which distort the signal waveforms.

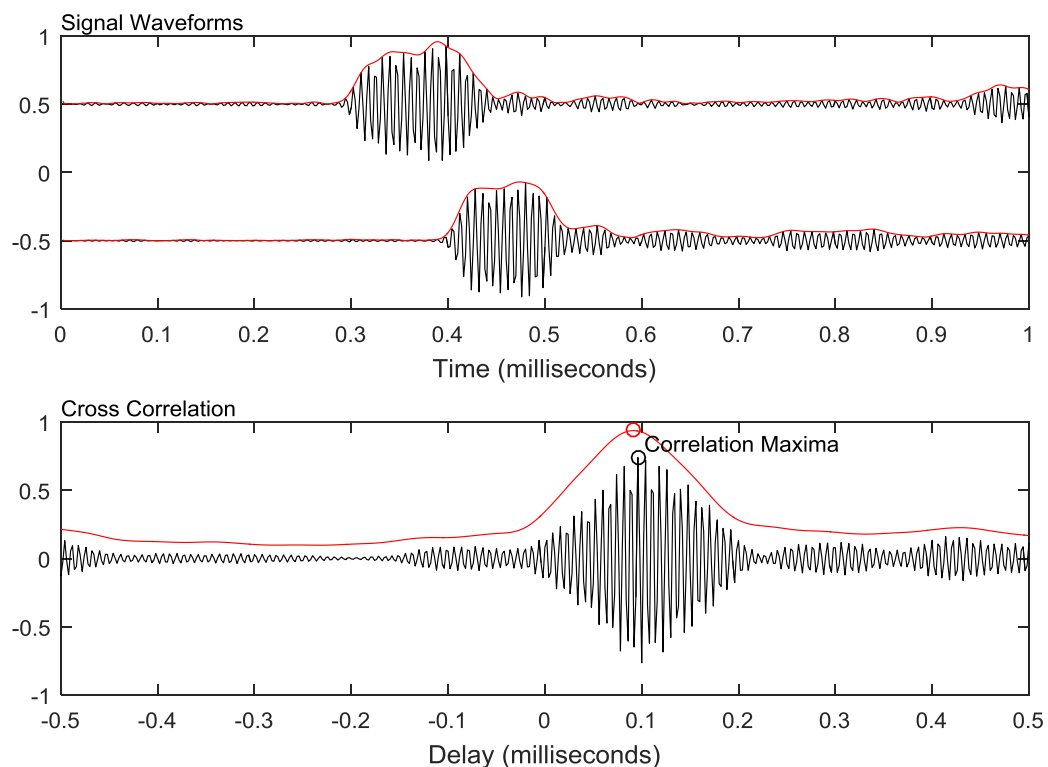

Figure 51: Porpoise signal waveforms on two channels and their cross correlation function (black lines). Also shown are the waveform envelopes and cross correlation function of the waveform envelopes (red lines). The time delay is taken as the maximum of the cross correlation function which in this example is around 0.1 ms.

Figure 52 shows the differences between successive time delay measurements arising from artificial porpoise like clicks spaced 0.1 s apart. The sound source would have moved a negligible distance in this time, so time delay measurements should be nearly identical. This is consistent with the strong peak in Figure 52 at

zero time difference, which has a width of around $0.3\mu\text{s}$, i.e. less than $1/6$ of a sample. However, several other peaks are visible to the right and left of the central peak, representing measurements where the cross correlation is 1, 2 or 3 cycles of the waveform out. For porpoise clicks, 30% of timing measurements lie in these secondary peaks of the timing histogram. The standard deviation for time differences is $8\mu\text{s}$ (excluding a small number of outliers with gross timing errors $> 50\mu\text{s}$). Assuming independence between the timing errors on each click, this suggests a timing error on each measurement of around $5\mu\text{s}$.

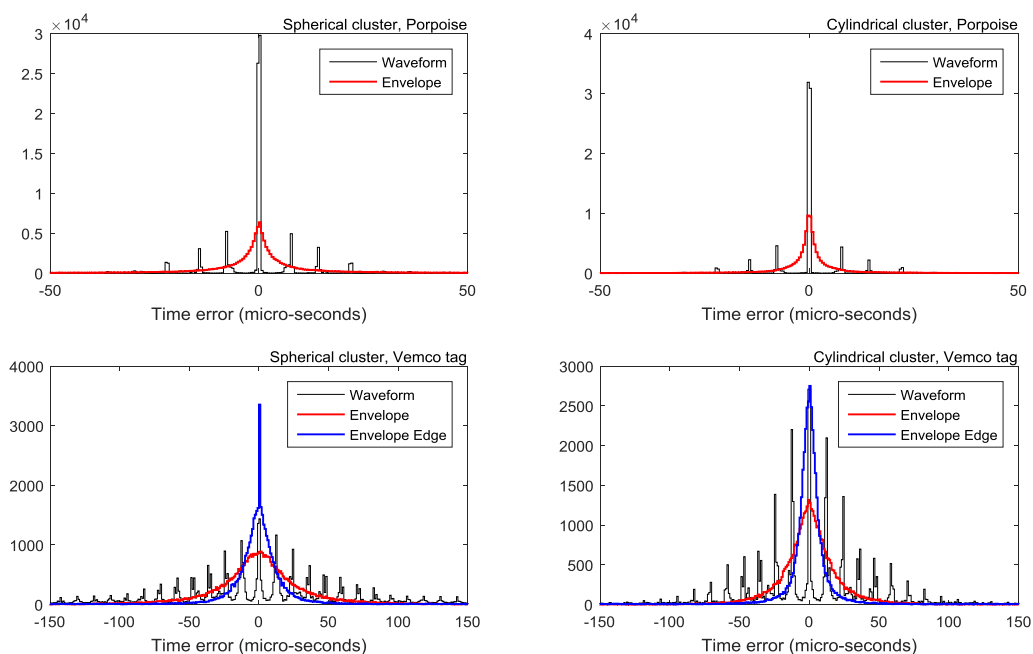

Figure 52: Timing differences between adjacent clicks for different click types on the two hydrophone clusters from Calibration trials conducted in the Sound of Sleat. Note the different horizontal scales used for the porpoise clicks and VEMCO tags (porpoise click timing being more accurate than VEMCO tag timing).

For the longer duration VEMCO tag signals (Figure 53) the cross correlation function contains many peaks with similar maximum values and it becomes even harder to select the correct one. This problem is exacerbated by signal distortion caused by echoes from nearby structures which start to arrive and distort the signal long before the original pulse has been captured. Figure 52 also shows timing errors calculated in the same way for VEMCO tags. Clearly the number of timing measurements with a large error, caused by the wrong peak being selected, is much greater than that for the shorter porpoise clicks.

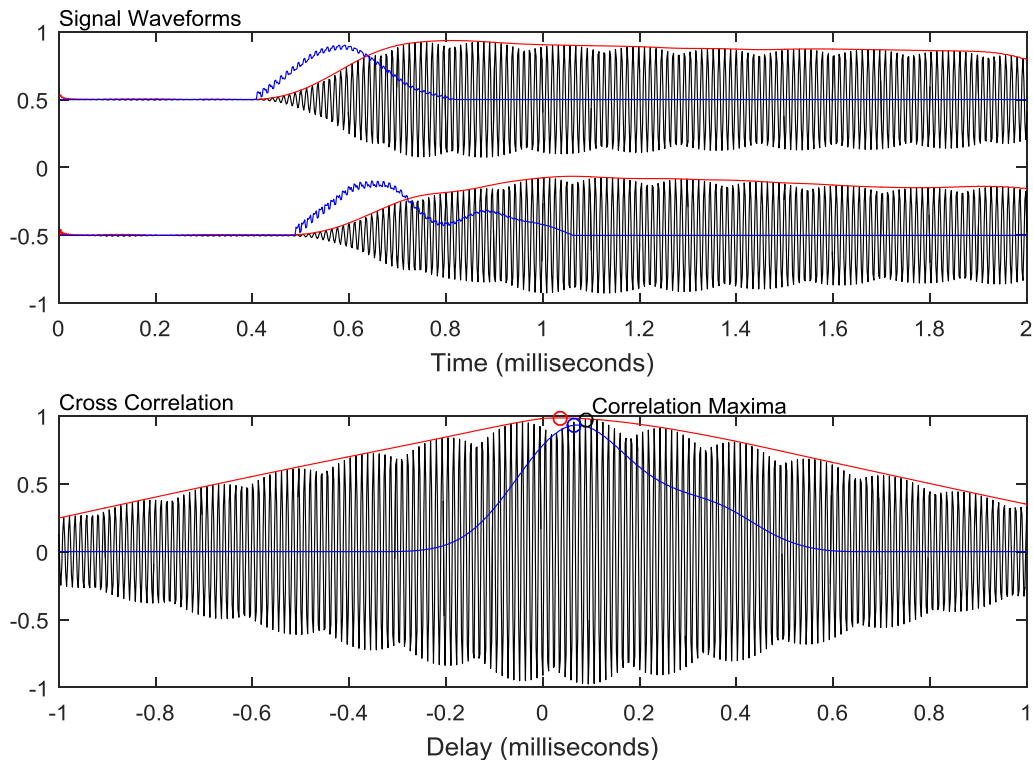

Figure 53: Signal waveforms (black), envelopes (red) and leading edge envelopes (blue) (top Panel) and their cross correlation coefficients (bottom panel) for signals from a VEMCO tag. Note the multiple similar sized peaks on the waveform cross correlation. The peak of the correlation functions based on waveform envelope (red lines) and on the leading edge of the waveform envelope (blue lines) are clearly better defined.

An alternative to cross correlating the signal waveform is to cross correlate the waveform envelope. The waveform envelope (also known as the analytic signal, shown in red in Figure 51 and Figure 53), is calculated from the Hilbert transform of the original waveforms. Cross correlations derived from the waveform envelope tend to have a single peak rather than multiple peaks, meaning that identification of the wrong peak is unlikely. However, there is the trade-off that the broader nature of the single peak, also means that the maximum of that peak is less well defined. For the porpoise click example in Figure 51 the timing difference between the two methods is 1.4 samples, whereas for the VEMCO pings it is 26 samples.

Another refinement when using the waveform envelope for cross correlation is to use only the rising edge of the envelope. This is advantageous because the rising edge is the part of the signal least likely to be distorted by echoes and reverberation. To find the leading edge, the first derivative of the envelope is taken and the first peak identified. The extent of the first peak is then taken as being the part of the envelope derivative for which that first peak is above zero and all data outside that first peak are set to zero (blue line in Figure 53, top panel). Timing accuracy for porpoise-like clicks and VEMCO tags for different correlation methods are presented in the main

body of this report, Section 5.2.2, Table 8. For porpoise clicks, using the waveform envelope made little difference to timing accuracy. However, for the VEMCO tag signals, using the leading edge of the waveform envelope reduced timing errors by a factor three.

Integration of this new timing method into the PAMGuard software is described in Section 5.4.1.

Appendix B

Seal Depth Calculation from Vertically Offset Multi-beam Sonars

The vertical beam pattern of the sonars was measured by lowering and raising the seal vertically through the swathe of one of the sonars; the relationship between the measured intensity on the sonar and both the angle of declination (degrees) and the range (metres) from the sonar heads (measured using the depth of the OpenTag together with the measured distance on the sonar) was modelled in a generalised linear model with Gaussian errors and an identity link function. The best fit model of the patterns of intensity of the grey seal carcass was described by Equation 1. The resultant model functions ($\pm 95\%$ CIs) are shown in Figure 54.

Equation 1:

$$SI = 987.6 - (0.13 \times \alpha^2) - (577.5 \times \log_{10} d)$$

Where:

SI is the relative intensity of the seal measured on the sonar,

α is the vertical angle of the seal in degrees relative to the centre of the vertical beam of the sonar,

d is the range in metres of the seal from the sonar.

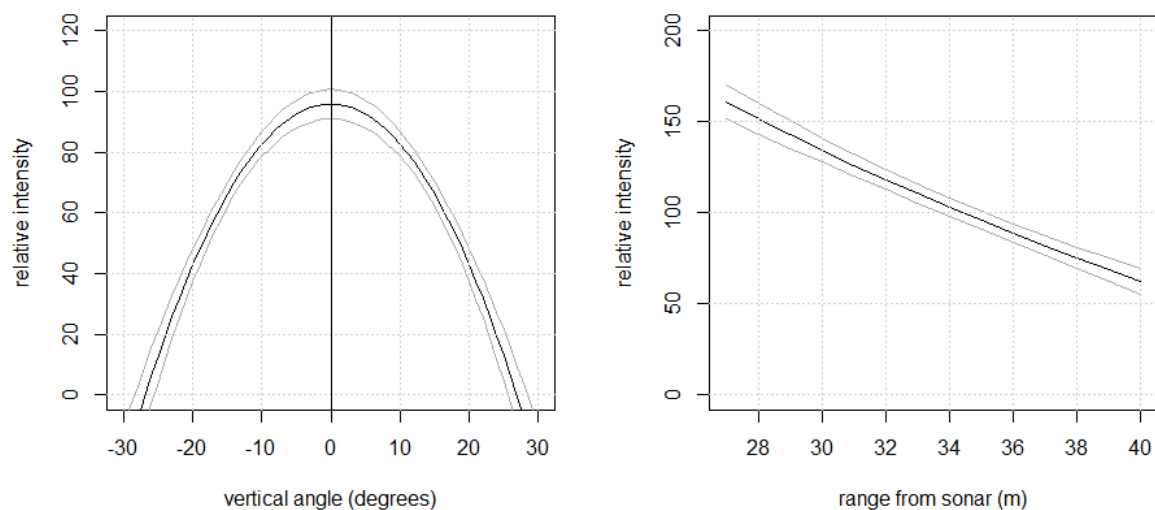

Figure 54: Patterns of signal intensity of a grey seal measured on a 720 kHz multibeam imaging sonar. The figure shows the best fit model functions ($\pm 95\%$ CIs) of a Generalised Linear Model (GLM) of the intensity values with vertical angle through the sonar swathe and with range from the sonar.

The second sonar was then mounted alongside the first and was orientated in the same horizontal angle but was orientated vertically with an offset angle of 17° . This provided an area where the swathes of the two sonars overlapped and the seal could be detected on both sonars (Figure 55). Over the period when the seal was visible on both sonars, the peak intensity of the seal was measured on each sonar at one second intervals and the ratio of intensities between the sonars was computed (Figure 56). The angle of declination of the seal from the water surface was calculated by comparing the intensity ratios to the expected ratios based on the modelled vertical beam pattern of the sonars (Figure 56). These angles, together with the measured ranges of the seal from the sonar, provided the information to calculate the depth of the seal at one second intervals. These depths were then divided into vertical tracks (where the seal was detected continuously on both sonars). Each vertical track was smoothed using a uni-variate penalized cubic regression spline smooths implemented using the package ‘mgcv’ (Wood, 2006) in the statistical software R (R Core Development Team, 2012) to produce a series of modelled depths (\pm 95% CIs) for each vertical track. Modelled depths were then compared to those measured on the depth logger to estimate the accuracy of the method for predicting dive depth.

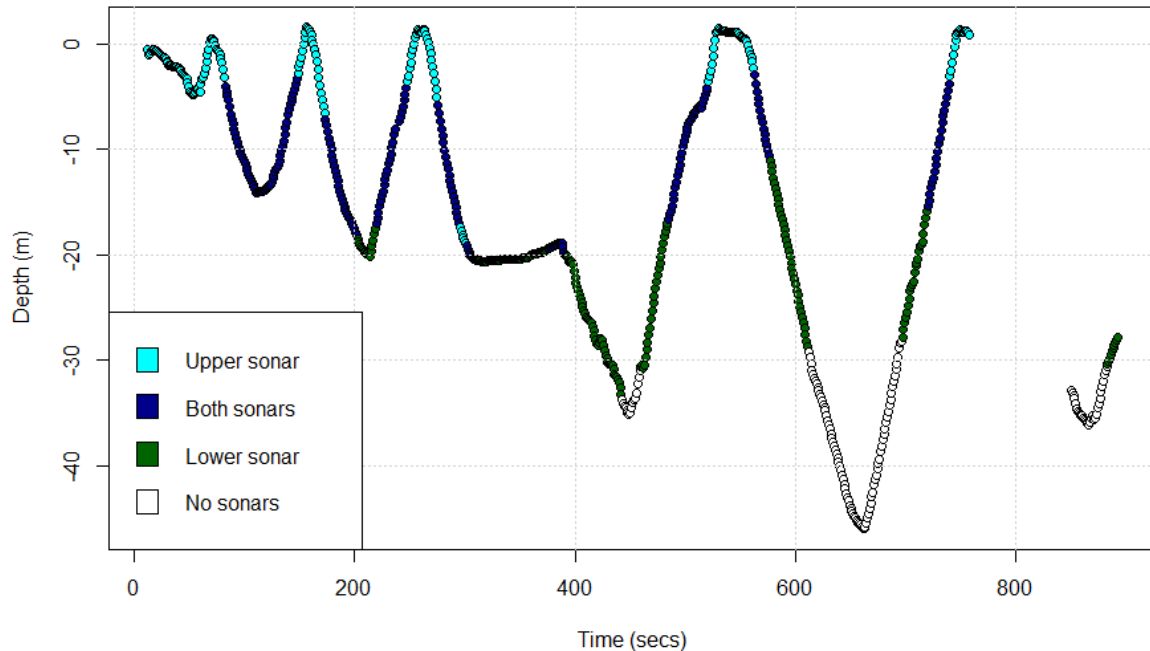

Figure 55: The depth measurements from the depth logger affixed to the grey seal carcass as it was lowered and raised through the dual sonar beams at a range of between 27 and 40 metres from the sonar. The points are colour coded to show whether the seal was detected on the upper sonar only (light blue), both sonars (dark blue), the lower sonar only (green), and neither sonar (white).

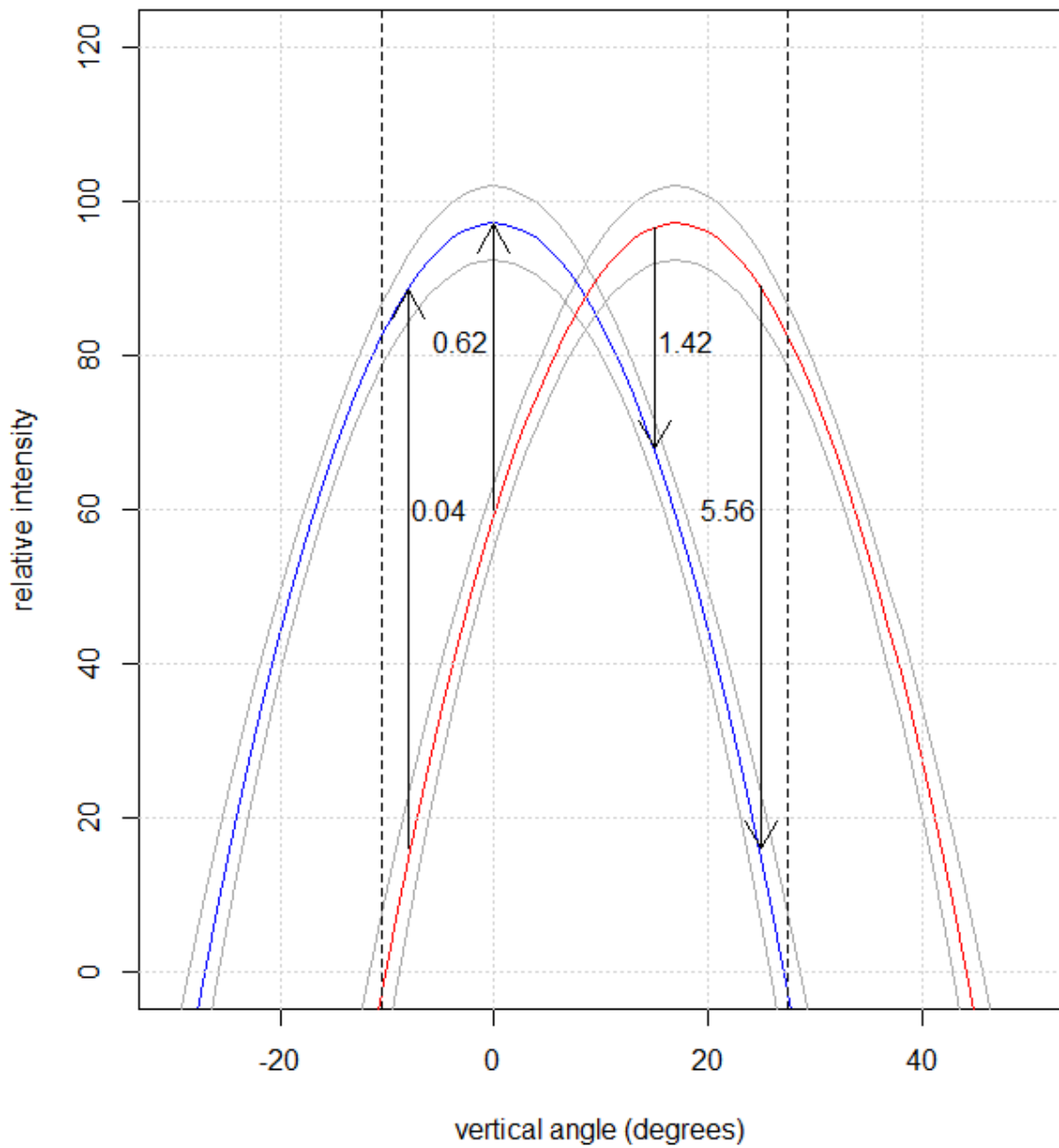

Figure 56: Example of the expected ratio of sonar intensities for a seal based on two 720 kHz multibeam imaging sonars offset by a vertical angle of 17 degrees. In this example, a ratio of less than, or greater than one would be expected if the seal was at a vertical angle less than, or greater than 8.5 degrees from the centre of the upper sonar respectively.